

USER'S AND MAINTENANCE MANUAL

MANUAL METAL BANDSAW

THOMAS ZIP 29 – ZIP 29 HB



Figura 1 - picture showing Zip 29 HB

Rev.2 del 15.11.2021 (Updated blade speed for 1PH 230V version)
Rev.1 del 15.04.2021 (Added data / wiring diagram for 1PH 230V version)
Vers. 1.0 del 16.02.2016

<ORIGINAL INSTRUCTIONS>

Information contained in this manual < ORIGINAL INSTRUCTIONS > is produced by the manufacturer.

STHEMMA s.r.l.
Via Monte Cimone 1, 36010 Zanè (VI) ITALY - T +39 0445 296303
P.IVA / VAT NR. IT03753910243

Our new web site is now online! <http://www.sthemma.com/>

CONTENTS

1	INFORMATION ON USER'S MANUAL.....	4
1.1	SIGNS ON THE MACHINE.....	4
2	MANUFACTURER, MACHINE DETAILS and DECLARATIONS.....	4
2.1	MANUFACTURER.....	4
2.2	DISTRIBUTOR.....	5
2.3	MACHINE DETAILS.....	5
2.4	'CE' PLATE.....	5
2.5	CONTENTS of "CE" CERTIFICATE OF CONFORMITY.....	6
2.6	NOISE TEST.....	6
2.7	DETERMINATION of VIBRATION LEVEL.....	7
3	GUARANTEE and SPARE PARTS REQUEST.....	7
3.1	GENERAL CONDITIONS.....	7
3.2	OPERATION LEADING GUARANTEE CANCELLATION.....	8
3.3	SERVICE INTERVENTION REQUEST UNDER GUARANTEE.....	8
3.4	SPARE PART REQUEST.....	9
4	GENERAL DESCRIPTION OF THE MACHINE.....	9
4.1	MACHINE OVERVIEW.....	9
4.1.2	SAWFRAME.....	10
4.1.3	VICE.....	11
4.1.4	BASE.....	13
4.1.5	ELECTRIC BOX and CONTROL PANEL.....	14
5	TECHNICAL DETAILS.....	15
5.1	TECHNICAL DATA.....	15
5.2	CUTTING CAPACITY.....	15
5.3	MAINS TOLERANCE.....	15
6	INTERACTIONS BETWEEN MACHINE and OPERATOR.....	16
6.1	CLASSIFICATION OF THE OPERATORS.....	16
6.2	MACHINE WORKING PLACE.....	17
6.3	DESCRIPTION OF THE WORKING PLACE.....	18
6.3.1	CONTROL PLACE.....	18
6.3.2	WORKING PLACE.....	18
6.4	SUITABLE USE and UNSUITABLE USE.....	19
6.4.1	SUITABLE USE.....	19
6.4.2	UNSUITABLE USE.....	20
6.4.3	CLAUSE of MANUFACTURER'S SAFEGUARD.....	20
6.5	GENERAL ADVISES on SAFETY and PREVENTION.....	21
7	GUARDS, PROTECTION DEVICES and SIGNS.....	22
7.1	GUARDS and PROTECTION DEVICES.....	22
7.2	SAFETY SIGNS ATTACHED TO THE MACHINE.....	24
8	REMAINING RISKS.....	25
8.1	SPOTS or DANGEROUS AREAS ON THE MACHINE.....	25
8.2	PERSONAL PROTECTION DEVICES.....	30
9	MOVING.....	31
9.1	GENERAL ADVISES.....	31
9.2	DELIVERY OF THE MACHINE.....	31
9.3	MOVING THE MACHINE WITH FORK LIFT TRUCK.....	32
9.3.1	MOVING THE MACHINE WITH FORK LIFT TRUCK.....	32
9.3.2	MOVING THE MACHINE WITH OVERHEAD CRANE.....	32
9.4	TRANSPORTATION OF THE MACHINE.....	32
10	INSTALLATION OF THE MACHINE.....	34
10.1	GENERAL ADVISE.....	34
10.2	AMBIENCE CONDITIONS.....	34
10.3	PREPARATION OF INSTALLATION PLACE.....	34
10.4	ANCHORAGE OF THE MACHINE.....	35
10.5	ELECTRIC CONNECTION TO THE MACHINE.....	35
10.6	MOUNTING PARTS AND ACCESSORIES SEPARATELY DELIVERED.....	37
11	USE OF THE MACHINE.....	38

11.1	GENERAL ADVISES	38
11.2	CHECK EFFICIENCY OF SAFETY DEVICES	39
11.2.1	EMERGENCY PUSH-BUTTON	40
11.2.2	INTERLOCKING ON THE SAWFRAME COVER.....	40
11.3	ADJUSTMENTS ON THE MACHINE	41
11.3.1	BLADE TENSION	41
11.3.2	ADJUSTMENT OF BLADE-GUIDE BLOCKS	42
11.3.3	VICE ADJUSTMENT	43
11.3.4	ADJUSTMENT OF THE CUTTING ANGLE (MITRE)	44
11.3.5	BLADE REPLACEMENT.....	45
11.4	START AND USE OF THE MACHINE	46
11.4.1	ADVISES FOR THE MACHINE USE	46
11.4.2	WORKING CYCLE	47
11.4.3	DESCRIPTION OF THE CUTTING CYCLE.....	47
11.4.4	CUTTING CYCLE	47
11.4.5	CUTTING CYCLE with OPTION “HB” CONTROLLED SAWFRAME DOWNFEED	49
12	<i>MAINTENANCE OF THE MACHINE</i>	50
12.1	GENERAL ADVISES	50
12.2	REGULAR MAINTENANCE	51
12.2.1	BLADE CLEANING BRUSH.....	52
12.2.2	REPLACEMENT OF SAWFRAME RETURN SPRING	52
12.2.3	DAILY MAINTENANCE	52
12.2.4	WEEKLY MAINTENANCE.....	53
12.2.5	MONTHLY MAINTENANCE.....	54
12.2.6	BIANNUAL MAINTENANCE.....	55
12.2.7	OIL COOLANT LIQUID	55
12.2.8	OIL DISPOSAL	55
12.3	SPECIAL MAINTENANCE	55
12.4	OUT OF SERVICE.....	55
13	FINAL INSTRUCTIONS	55
13.1	GENERAL ADVISES	55
13.2	MACHINE DISPOSAL.....	56
13.2.1	GENERALS INSTRUCTION FOR MATERIALS DISPOSAL	56
13.2.2	ELETCTRIC OPERATIONS.....	56
13.2.3	MECHANIC OPERATIONS.....	56
13.3	MODIFICATIONS	57
13.4	SALE	57
14	MATERIAL CLASSIFICATION AND BLADE CHOICE	57
14.1	DEFINITION OF MATERIALS	57
14.2	BLADE SELECTION.....	57
14.3	TEETH PITCH	58
14.4	BLADE SPEED and DOWNFEED SPEED	58
14.5	BLADE RUNNING-IN	58
14.6	BLADE STRUCTURE.....	58
14.7	BLADES TYPE.....	59
14.7.1	TEETH FORM and GEOMETRY	59
15	TROUBLE-SHOOTING	61
15.1	BLADES AND CUTS	62
15.2	ELECTRIC PROBLEMS	63
16	ELECTRIC DIAGRAMS	64
17	SPARE PARTS	65

1 INFORMATION ON USER'S MANUAL

- This manual is to be regarded as integral part of the Thomas Bandsawing Machine “ZIP 29” (further named “machine”) built by Sthemma Srl (further named “manufacturer”).
- The manual is an essential tool for the use and maintenance of the machine. It is law mandatory and for the use and maintenance of the machine. The user is legally bound to observe both prescriptions and advises contained therein.
- The manual is to be held all through the machine life. In case of loss or damage a copy must be requested to the manufacturer.
- The information contained in this manual are intended to reduce any risk for the operator's safety to a acceptable minimum.
- The user is bound to inform, form and train the operators about the content of this manual. Should the owner of user change during the machine life, this manual will accompany the machine.

1.1 SIGNS ON THE MACHINE



1) Obligation: wear protection gloves.



2) Obligation: wear protection glasses.



3) Obligation: wear protection shoes.



4) Obligation: wear protection helmet.



5) Obligation: wear protection worker's cloth.



6) Obligation: wear ears protection plugs.



7) Interdiction: do not lubricate and clean during machine running.



8) Interdiction: do not use the machine without safety devices.



9) Presence of electrified components: risk of electric shock.



10) Danger pay utmost attention:

a) DANGER: warning against incorrect use which may cause serious injury, death or long term risk for the operator.

b) WARNING: incorrect operation may cause serious injury, death or long term risk for the operator.

c) CAUTION: incorrect operation may cause damage or downtime for the machine.

2 MANUFACTURER, MACHINE DETAILS and DECLARATIONS

2.1 MANUFACTURER

- Name: STHEMMA SRL.
- Address: Via Monte Cimone, 1 – 36010 ZANE' (VI) – Italia
- VAT registration number: IT003753910243
- Tel.: +39 (0445) 296303
- Fax: +39 (0444) 976934

2.2 DISTRIBUTOR

- Name: _____
- Address: _____
- Tel.: _____
- Fax: _____

2.3 MACHINE DETAILS

- Machine Type: METAL BANDSAWING MACHINE
- Model: ZIP 29
- Year of Construction: 2016
- Weight of the machine: 215 kg

These details are to be found on the machine 'CE' label.

2.4 'CE' PLATE

'CE' plate is punched on the right side of the machine (fig. 1-2). This label contains the details prescribed by paragraph. 1.7.3 of the Annexure 'I' of the Machine Directive.

- Name and full address of the manufacturer.
- 'CE' label.
- Type of the machine.
- Model Name.
- Serial Number.
- Year of Construction.
- Weight of the machine.

Distributor, if any, is to stick a label containing his own details beside to the 'CE' plate.



Fig. 1-2

2.5 CONTENTS of “CE” CERTIFICATE OF CONFORMITY

STHEMMA SRL
 Via Monte Cimone, 1
 36010 ZANÈ (VI) - ITALIA
 Partita I.V.A. IT03753910243

We declare under our own responsibility that the machine

Type:	Metal Bandsawing Machine
Model:	ZIP 29
Serial Number:	XXXXXXXXXXXXXXXXXX
Year of Construction:	XXXX

Which this declaration refers to, is conform to the essential safety regulations contained in the following directives:

- 2006/42/CE Machine Directive
- 2014/30/UE Electromagnetic Compatibility

For the assessment of the conformity the above mentioned regulations, the following harmonized rules have been adopted:

- UNI EN ISO 12100:2010
- EN 60204-1:2016

For the assessment of the conformity, the manufacturer went through the procedure with internal inspection of the machine construction as per Annexure VIII. Note that the machine is not contemplated in the Annexure IV.

Technical documentation is held by STHEMMA Srl and it will be available on request to the member of the board of directors Paola Calli domiciled via Monte Cimone 1 Zanè , 36010 (VI).

Zanè: _____

Signed by:

Paola Calli

as:

Procurator

Signature:

2.6 NOISE TEST

Noise generated by the machine is definitely affected by its equipment, blade condition, running speed and type / form of the material being cut. Moreover, the noise generated indoor by the presence of nearby machines is affected by the reflection, absorption and acoustic dispersion of the hall walls, ceiling, floor and other objects.

According to Regulation EN ISO 16093, Noise Tests have been carried out and the following report certified.

Metal Bandsawing Machine Thomas Model: ZIP 29
 Blade Speed: 70 m/min.
 Material being cut during the test: Steel Bar UNI C40 Ø 50 mm

Place: manufacturer's factory		
ACOUSTIC EMISSION		
According to Regulation EN ISO 4871 e EN ISO 16093		
	A vuoto (dB)	In taglio (dB)
Weighted Acoustic Power Level A (Lwa)		
Weighted Acoustic Pressure Level A at working place (Lpa)	64,4	73,8
Peak Weighted Acoustic Pressure Level C at working place (Lpc)	< 130	< 130
Incertitude Value = 4 dB for the tests effected According to Regulation EN ISO 3746.		
Values reported according to the procedures for Noise Tests as indicated by EN ISO 11202 and regulation EN ISO 3746. All tests referring to the appendix A and B of regulation EN ISO 16093 (machine-tools – Safety– Metal Cold Saws).		
Note. The amount of the acoustic value and the relevant incertitude represents the maximum value reported during the tests.		

The above mentioned values are emission levels and not necessarily safe working levels. Although there is a relationship between emission and exposure levels, this can't be taken as a proof to state if additional precautions are to be implemented or not. Factors affecting the actual exposure level of the worker are the presence of nearby machines and other works in progress.

Moreover, admitted exposure levels may vary in different countries. However, these tests are meant to help the user in evaluating danger and risk more accurately.

ATTENTION

Since the noise generated by the machine depending from the material to cut and blade conditions as well, the user is bound to test the noise of the machine and adopt the means to reduce it to avoid loss of the operator's acoustic power caused by extended noise exposure.

2.7 DETERMINATION of VIBRATION LEVEL

Vibration Tests have been carried out to determine the exposure level of Hand/Arm. The measurements have been performed according to the regulation EN ISO 20643.

For the Vibrations transmitted to Hand/Arm, the maximum level of daily exposure through 8 hours has been set to 5 m/s^2 , whilst the daily action value through 8 hours has been set to $2,5 \text{ m/s}^2$.

The following tests have been carried out:

- 1) Sawing a steel bar section 20x40 mm: total value of measurement showing $0,24 \text{ m/s}^2$.
- 2) Sawing s steel pipe $\varnothing 80$ thickness 5 mm: total value of measurement showing $0,43 \text{ m/s}^2$.

Total level of vibrations transmitted to operator's Hand/Arm showing lower than $2,5 \text{ m/s}^2$, hence lower than action value.

3 GUARANTEE and SPARE PARTS REQUEST

3.1 GENERAL CONDITIONS

- The machine is guaranteed through 12 months counting from the delivery date. In any case, a registered letter is to be sent to the manufacturer within 8 days from the fault finding. The manufacturer has the right to assess the fault and agree or disagree on any claim.

- Guarantee includes the replacement or repair of the faulty part (component, machine or part of it) with the exception of dismounting, mounting and shipment costs.
- The replacement of such a part does not lead to a renewal of the guarantee of the machine excepted in case of replacement of the complete machine.
- The replaced part should be sent back to STHEMMA Srl as soon as possible.
- After that, the manufacturer is not bound to any reimbursement and the purchaser is not entitled to any refund for damages or costs to third parties included and renounces to any claim caused by machine stop or production loss.
- Guarantee does not cover consumable parts like blade, brush, pads etc. or deterioration caused by atmospheric agents and external conditions or products being used. Damages caused by lack or insufficient/incorrect maintenance, incorrect/improper use, not allowed/not expected use, technical modifications or unauthorized repair.
- Validity of guarantee is subordinated to correct maintenance as described at Chapter MAINTENANCE.
- Guarantee is null if payment conditions are not fulfilled completely.
- Third parties supplied parts are subjected to their own guarantee conditions
- For any controversy or dispute the competent Law Courts is Vicenza of Italy and this shall have exclusive jurisdiction.

NOTES

- Special Guarantee Clauses should be expressly mentioned in the sale contract.
- Use of Non Original Parts lead to cancellation of Guarantee.

3.2 OPERATION LEADING GUARANTEE CANCELLATION

- Lifting and moving of the machine not according to the instructions given at the Chapter. MACHINE MOVING and/or carried out from unskilled operators.
- Installation of the machine not according to the instructions given at the Chapter. INSTALLATION and/or carried out from unskilled operators.
- Electric Connection not according to the instructions given at the Chapter. ELECTRIC CONNECTION and/or carried out from unskilled operators.
- Mounting Assemble of separated delivered parts and accessories not according to the instructions given at the Chapter MOUNTING PARTS ANS ACCESSORIES and/or carried out from unskilled operators.
- Machine use performer by unskilled operators (see Chapter. CLASSIFICATION OF THE OPERATORS).
- Nor allowed machine use (see Chapter. ALLOWED USE / UNEXPECTED USE).
- Adjustment of the machine not according to the instructions given at the Chapter ADJUSTMENTS OF THE MACHINE and/or carried out from unskilled operators.
- Maintenance of the machine not according to the instructions given at the Chapter MAINTENANCE OF THE MACHINE and/or carried out from unskilled operators..
- Use of not original parts or non original spare parts or not authorized by the manufacturer.
- De-installation of the machine carried out from unskilled operators.

3.3 SERVICE INTERVENTION REQUEST UNDER GUARANTEE

- Parts or service intervention under guarantee must be addressed to the manufacturer or distributor immediately upon fault finding as shown on the Chapter GENERAL CONDITIONS.

- Always mention type, model and the serial number of the machine when requesting spare parts or service intervention under guarantee. These details are to be found on the machine identification plate.

NOTE

Inobservance to the instructions given in this manual will raise the manufacturer from any responsibility in case of accident, injury to workers or damages and malfunctioning of the machine.

3.4 SPARE PART REQUEST

Any request for spare parts should be notified with the following details:

1. Model of the machine.
2. Serial Number of the machine.
3. Part Number shown on the exploded view contained in the manual.

Should these details missing, WE WILL NOT BE ABLE to supply any part.

See Chapter SPARE PARTS.

4 GENERAL DESCRIPTION OF THE MACHINE

Bandsawing machine THOMAS ZIP 29 is a manual horizontal bandsaw with swing sawframe for easy mitre cutting. Single mitre 0-60° R. Optional 'DA' hydraulic controlled sawframe downfeed. The machine is made up of the following assemblies: Sawframe, Vice, Base, Electric Box and Control Panel. Accessories are also an integral part of the machine.

The **sawframe**, in cast-iron, is hinged on a supporting arm allowing manual pull down and lifting by hand after the cut with the help of a special spring. **Optional 'HB'** allows gravity sawframe descent hydraulic controlled so the machine can be left cutting unattended.

The **sawframe** is equipped with one electric motor and two flywheels driving the blade and rotates one way for mitre cutting 0-60° to right. Stock material remains stationary.

The **vice**, in cast-iron, is mounted on the base and it is closed by a hand wheel.

The **base** of the machine in steel metal plate supporting the above mentioned assemblies.

The **electric box** is mounted on a steel bar and equipped with 2 blade speed switch.

4.1 MACHINE OVERVIEW

The machine is made up of the following assemblies (refer to fig. 1-4).

- 1) Sawframe.
- 2) Vice.
- 3) Base.
- 4) Electric Box.
- 5) Electropump for Coolant Liquid.

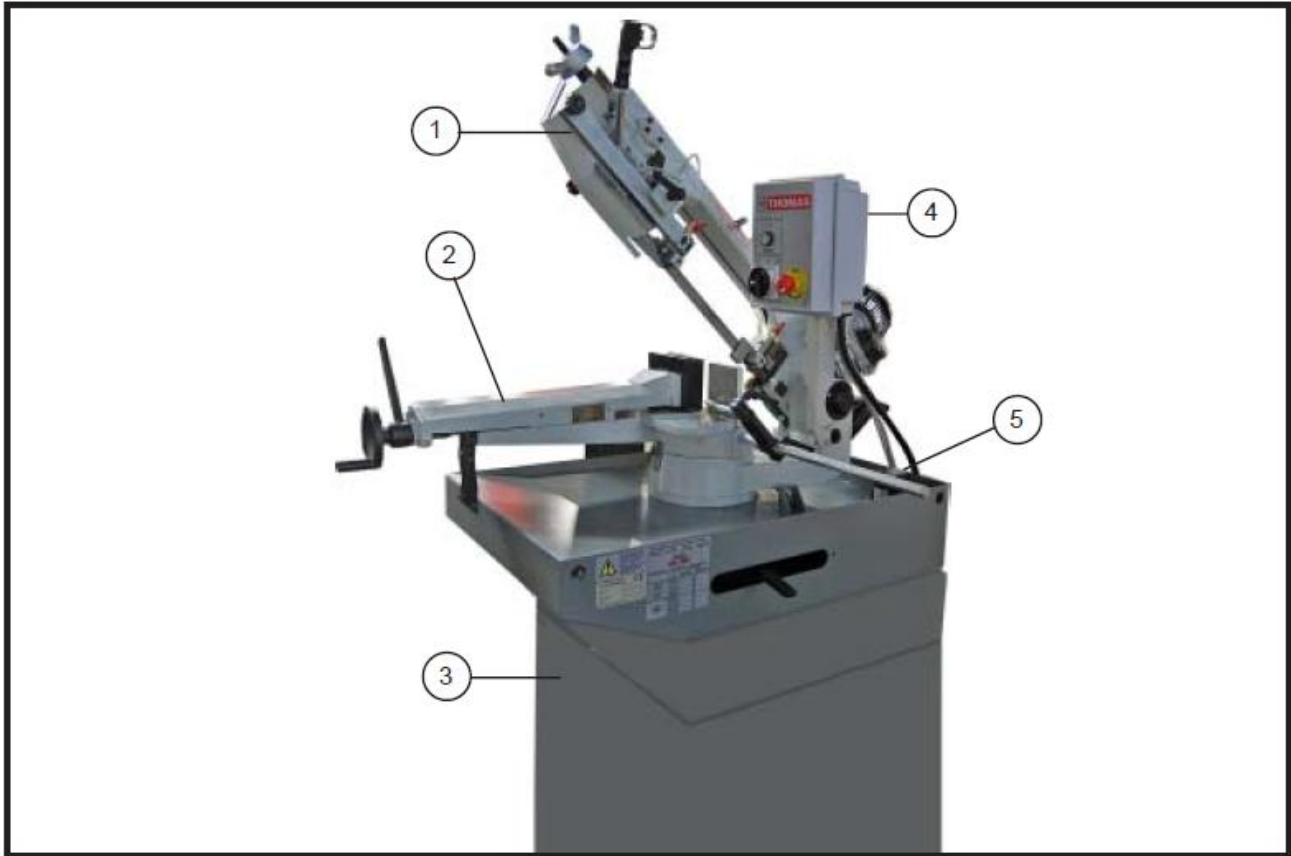

Fig. 1-4

4.1.2 SAWFRAME

Part of the machine holding operating parts (gear-box and flywheels), blade tension and blade guides. Refer to fig. 2-4.

- 1) Sawframe.
- 2) Motor and Gear-box.
- 3) Lock Lever for mobile blade-guide.
- 4) Steel guide-bar for mobile blade-guide.
- 5) Mobile blade-guide.
- 6) Metal Protection for mobile blade-guide.
- 7) Fixed blade-guide.
- 8) Metal Protection for fixed blade-guide.
- 9) Blade cleaning Brush.
- 10) Sawframe Metal Protection.
- 11) Micro-switch.
- 12) Sawframe.
- 13) Plastic Knob.
- 14) Motor Flywheel.
- 15) Return Flywheel.
- 16) Blade.
- 17) Hand Wheel for blade tension.
- 18) Trigger Switch for motor Start.
- 19) Tap for adjusting coolant liquid flow.

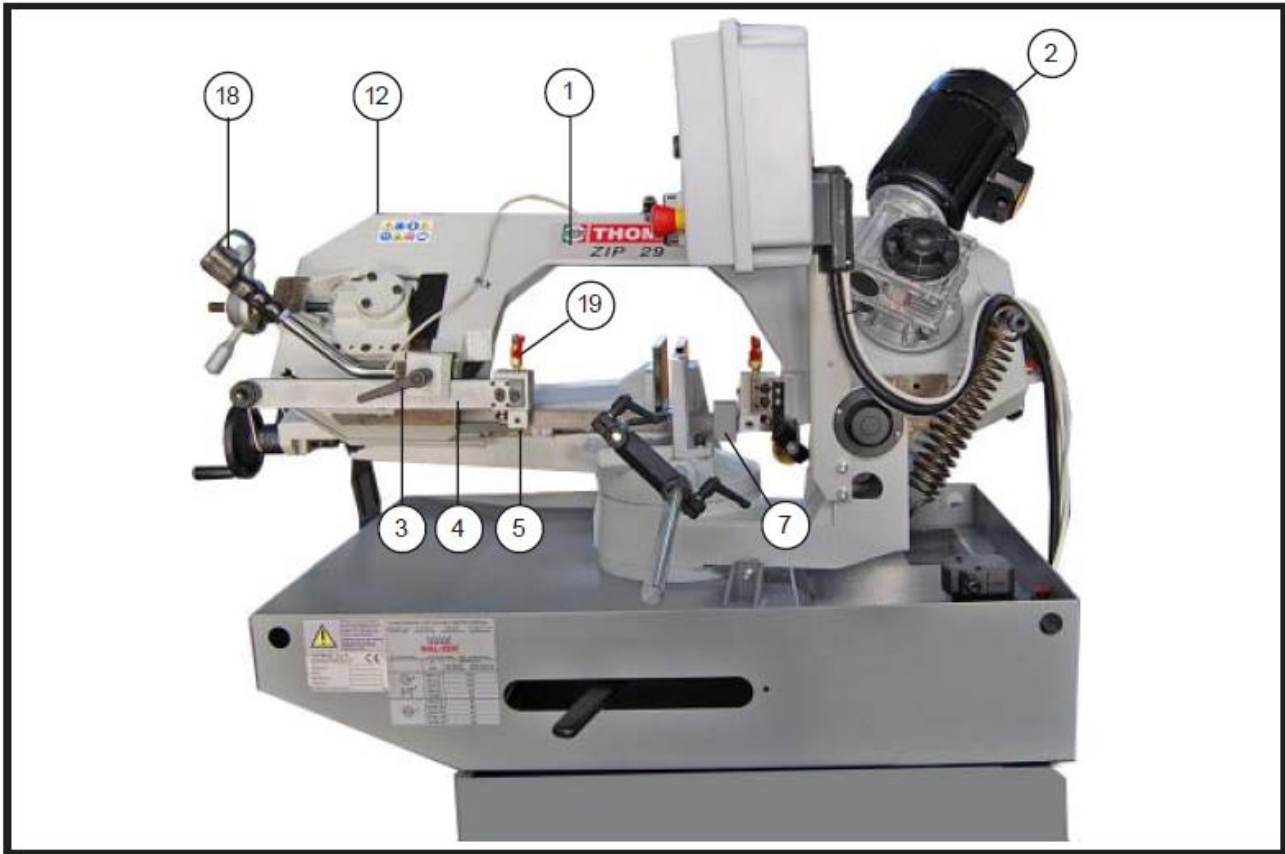

Fig. 2-4

4.1.3 VICE

Material clamp during cutting by hand wheel and quick lock lever. The Vice can be moved sideways right and left allowing mitre cutting. Refer to fig. 3-4.

- 1) Base.
- 2) Revolving Arm supporting the sawframe.
- 3) Back Scale showing mitre degree.
- 4) Lever locking revolving arm.
- 5) Working Table.
- 6) Left Jaw on countervise.
- 7) Right Jaw on countervise.
- 8) Vice Jaw.
- 9) Vice.
- 10) Lever for quick lock vice.
- 11) Vice Hand Wheel.
- 12) Spring for sawframe return.
- 13) Bar stop Rod.

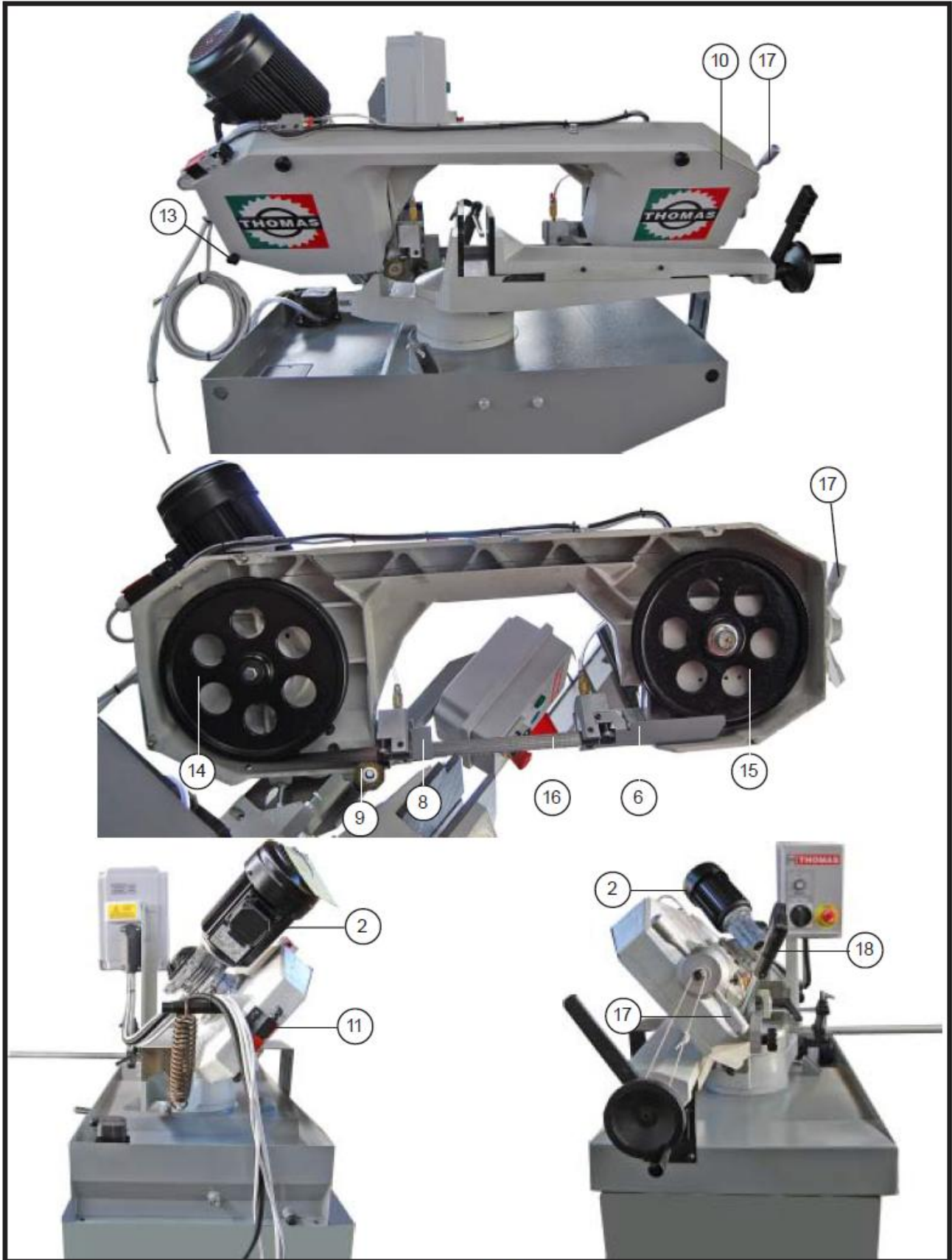

Fig. 2-4

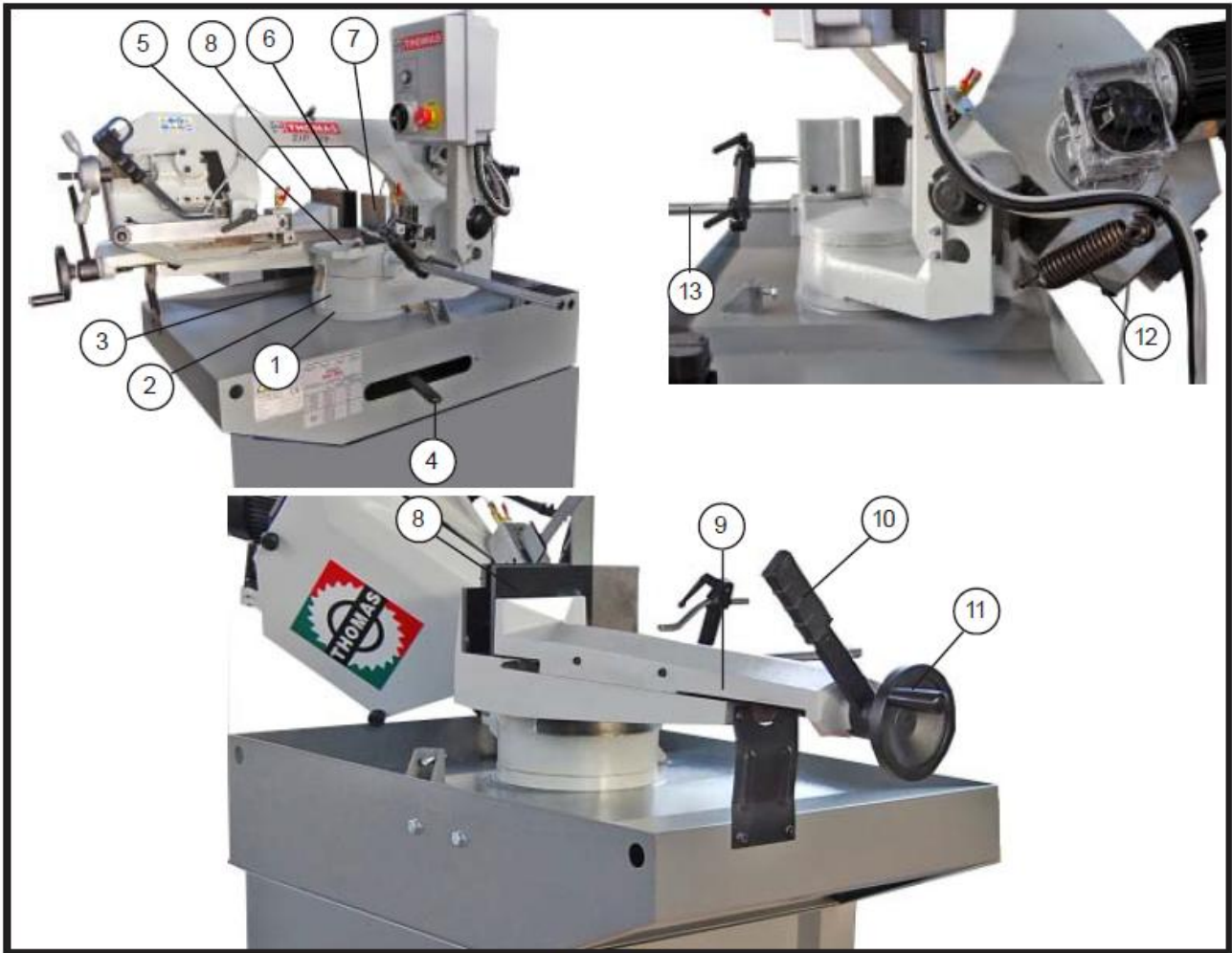

Fig. 3-4

4.1.4 BASE

Metal steel plate base supporting the revolving arm, vice and bar stop. Housing for coolant liquid Tank and Electropump.

Refer fig. 4-4.

- 1) Metal Work.
- 2) Coolant liquid Outlet.
- 3) Attachment for material support.
- 4) /
- 5) Filter for coolant liquid.
- 6) Drain for coolant liquid.
- 7) Level for coolant liquid.

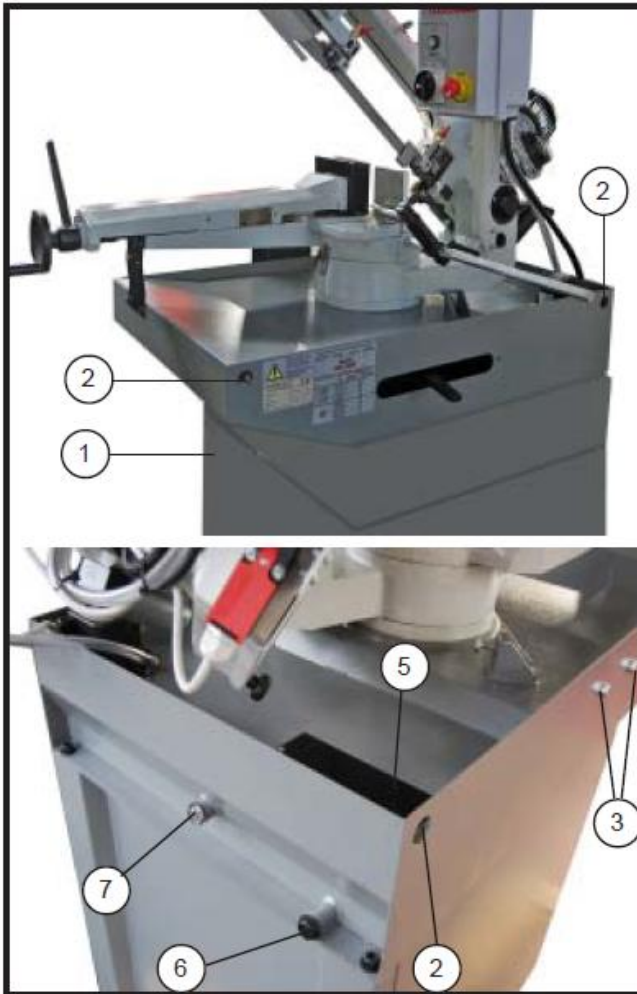

Fig. 4-4

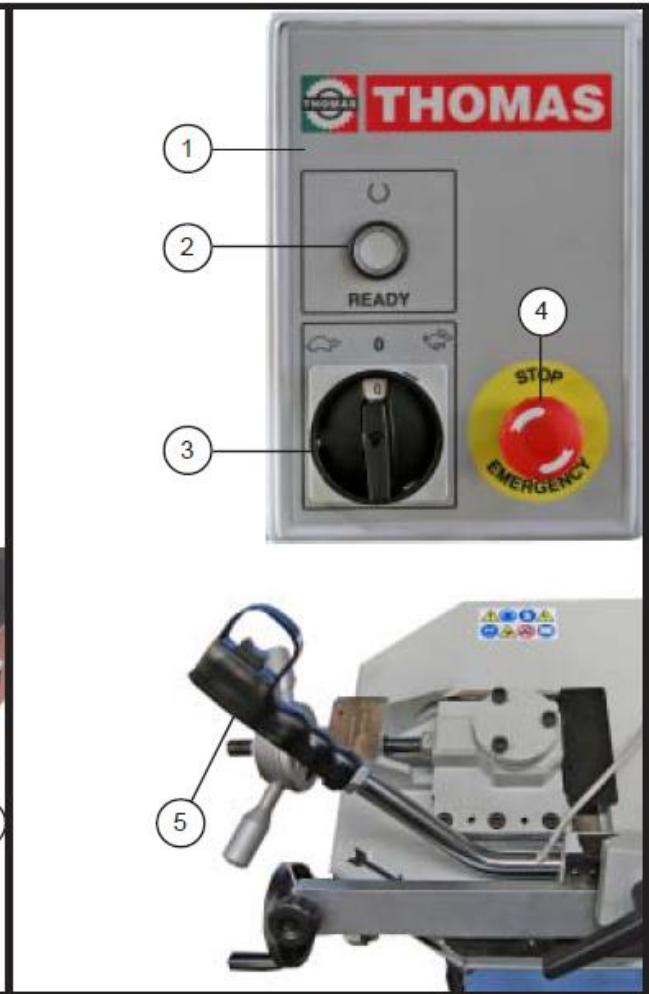

Fig. 5-4

4.1.5 ELECTRIC BOX and CONTROL PANEL

Refer to fig. 5-4.

- 1) Electric Box (plastic).
- 2) Luminous Push-Button for machine stand-by; when lit up the machine is electric energized and ready for use.
- 3) <1/0/2> Motor Speed Switch. Pos.1 = 35 m/min. Pos.2 = 70 m/min.<READY>
- 4) <EMERGENCY> Red Push-Button on yellow sticker. Machine stop in case of danger.

5 TECHNICAL DETAILS

5.1 TECHNICAL DATA

▪ Electric Motor controlling blade speed three-phase 400V kW	0,55 - 1,1
▪ Electric Motor controlling blade speed single-phase 230V kW	1,1
▪ Electropump..... kW	0,06
▪ Blade dimensions.....mm	2450x27x0,9
▪ Flywheels diameter.....mm	290
▪ Blade Speed three-phase..... m/min.	32 – 64
▪ Blade Speed single-phase m/min.	95
▪ Vice Opening.....mm	250
▪ Sawframe Inclination..... degree	40
▪ Working Table Height.....mm	980
▪ Mitre (cutting angles) degree	45°÷60°
▪ Mitre accuracy degree	± 0,1
▪ Machine Dimensionsmm	1400x750x1600
▪ Machine Weightkg	215
▪ Voltage Supply V	400 or 230
▪ Frequency Hz	50
▪ Max Absorption with three-phase motor..... A	2,1
▪ Max Absorption with single-phase motor A	11
▪ Coolant liquid Tank Capacity Liters	15

5.2 CUTTING CAPACITY

▪ Round 0°mm	225
▪ Round 45° R.mm	140
▪ Round 60° R.mm	60
▪ Square 0°mm	200x200
▪ Square 45° R.....mm	140x140
▪ Square 60° R.....mm	60x60
▪ Rectangle 0°mm	240x140
▪ Rectangle 45° R.mm	135x150
▪ Rectangle 60° R.mm	60x85

5.3 MAINS TOLERANCE

Voltage

Admitted Voltage: ± 10% of nominal voltage.

Frequency

± 1% of nominal frequency in continuous rating.

± 2% of nominal frequency for short time.

Harmonic Frequency

Harmonic distortion for the total of the harmonic frequencies from the second to the fifth not over 10% of the total voltage in efficient value between the energized conductors. Additional Distortion 2% is admitted for the total of the harmonic frequencies from the sixth to the thirtieth in efficient value between the energized conductors.

Voltage Unbalance for three-phase voltage supply

Both inverted sequence and zero sequence should not be over 2% of voltage direct sequence.

Voltage Pulsations

Voltage pulsations should not last longer than 1,5 ms by up and down time included between 500 ns and 500 µs with peak value not over 200% of the efficient value of nominal voltage supply.

Voltage Interruption

Voltage should not be interrupted nor go down to zero for more than 3 ms no matter what supply wave. The interruptions should not last more than 1 sec.

Voltage Downfall

Voltage Downfall should not go beyond 20% of the peak voltage supply for more than one cycle. The downfalls should not last more than 1 sec.

6 INTERACTIONS BETWEEN MACHINE and OPERATOR

According to the Annexure I of Directive 2006/42/CE and following modifications, the meaning of:

- «danger» is a cause of injury or serious health problem for the operators;
- «dangerous area» is any area within and/or in proximity of a machine by which the operator stands;
- «exposed people» is anyone standing within a dangerous area;
- «operator» is anyone in charge with installation, running, adjusting, cleaning, repair or moving the machine or doing maintenance works.
- «risk» is the combination of probability and seriousness of a injury or health issue which may occur in a dangerous area;
- «protection» is a component of the machine used to guarantee the protection by a material guard;
- «protection device» is a device other than a guard which reduces the risk as a single element or associated to a guard;
- «provided use» is the use of the machine according to the information contained in the user's manual;
- «incorrect use reasonably expected» is the use of the machine other than instructed from the user's manual, however easily predictable of a human behavior.

6.1 CLASSIFICATION OF THE OPERATORS**ATTENTION: the machine should be attended by N. 1 OPERATOR.**

- The machine should be used in professional areas only and the operator should be qualified and able to read and understand the instructions given in the user's manual. It is expected that the operator has the formation requested to maintain industrial machineries, therefore basic notions on maintenance have been omitted.
- The number of the operators in charge, relevant qualifications and intervention procedures are meant to guarantee the safety of the operators and the achievement of the production plan.
- The employment of an additional or fewer number of operators, having different or lower qualification, or the adoption of intervention procedures other than prescribed in this document, may cause serious danger for the safety of the operators and jeopardize the achievement of the production plan.

Machine Operator

Qualified worker properly formed on the machine, capable to operate on the machine and carry out the following operations

- a) Check safety devices before starting the machine;
- b) Load and Discharge the stock material;
- c) Start, drive and stop the machine with the buttons located on the control panel while the safety devices are active;
- d) Re-Start the machine after an emergency Stop;
- e) Clean the machine and refill coolant liquid into the tank.

Mechanic Engineer (Maintenance)

Qualified technician capable to drive the machine in normal conditions while the safety devices are active or disconnected, to make technical adjustment on mechanical parts, maintenance and repair works. He is not authorized to access the electric box.

Electric Engineer (Maintenance)

Qualified technician capable to drive the machine in normal conditions while the safety devices are active or disconnected, to make electric interventions on electric components, maintenance and repair works. He is authorized to make electric intervention while the electric box is energized.

Service Engineer from the Manufacturer

Qualified technician from the factory capable to make maintenance and/or repair works. Also capable to make special works or applications requested by the customer.

6.2 MACHINE WORKING PLACE

The machine has been designed and built to cut metallic materials in the form of bars and profiles of different sections. The operator is supposed to load the stock material on the vice manually; the stock material should be supported by roller tracks.

The cut of the stock material occurs in the area between the vice and the blade. The area in which the operation occurs is called "MACHINE WORKING AREA" (1 fig. 1-6).

ATTENTION

The machine working area is a dangerous area.

Four areas have been identified on the machine (fig. 1-6):

- 1) working area of the machine;
- 2) control area;
- 3) material loading area (for machine equipped with roller track too).
- 4) material discharge area (for machine equipped with roller track too).



Fig. 1-6

6.3 DESCRIPTION OF THE WORKING PLACE

6.3.1 CONTROL PLACE

Control place (1 fig. 2-6) is located in front of the control panel (2 fig. 2-6), on the front side of the machine. From this position the operator starts, stops and drives the machine, pulling down the sawframe to cut the material, opens and closes the vice.

From the control place, the operator can visualize the machine completely; therefore, he is able to make sure the nobody is around when the machine is started or during the cutting. In case of danger, the operator can stop the machine by pressing the emergency push-button (3 fig. 2-6) located on the control panel.

6.3.2 WORKING PLACE

Working place n. 1 (4 fig. 2-6) refers to the area in which the operator stands to load the stock material onto the vice (for the machine equipped with roller track too).

Working place n. 2 (5 fig. 2-6) refers to the area in which the operator stands to discharge the material off the vice (for the machine equipped with roller track too).

Normally, the stock material is not too heavy and the cut pieces are short and easy removable. The operator does not need to move from his control place.



Fig. 2-6

6.4 SUITABLE USE and UNSUITABLE USE

- The Use of the machine other than prescribed by the manufacturer might lead to dangerous events for people safety and risks of serious accidents. The machine itself can be damaged.
- Unsuitable use will raise the manufacturer from any responsibility in case of accident, injury to workers or damages and malfunctioning of the machine.
- Unsuitable use will also cancel the machine guarantee.

6.4.1 SUITABLE USE

The machine has been designed for cold metal cutting, metallic or partially metallic stock materials of different shape commonly use in workshops, mill and metal working in general: bars, profiles and metal plates / light alloys in round, square or rectangular shapes etc. Any other use is not allowed, except written manufacturer's authorization.

- The machine is for professional use only and the operators should have a certified permission to operate the machine. They should be able to read and understand the user's manual, trained and in perfect psycho-physical conditions.
- The normal use of the machine require the number of operators as prescribed by the chapter. CLASSIFICATION OF THE MACHINE OPERATORS.
- During the use of the machine the operator should stand as shown on fig. 2-6.

- For the machine to be used in a proper and safety way, roller tracks should be provided to support the stock material (these can be delivered from the manufacturer's optional accessories/equipment sales list). User can get roller tracks from any other make; however, the risk evaluation and the connection to the machine are to user's charge as well as caution and safety devices to avoid or reduce the relevant risks.
- Loading and Discharge of stock material onto and off the roller tracks would require a certain number of workers who may be employed by the user according to the available lifting devices and dimensions/weight of the stock material.
- Before starting the machine, the operator should check that all safety devices are in place and working well; also, that the machine working area is free from stranger objects and people are not around the machine.
- When the machine is running, the working area (area 1 fig. 1-6) is a dangerous area; the operator should **COMPULSORILY** stay away from the working area. Material loading and discharging should **COMPULSORILY** occur when the machine is at stop.
- Do not attempt to cut any material having larger dimensions than those shown on the chapter **TECHNICAL DATA**.
- The machine should be installed and used in-door and protected from atmospheric agents.

6.4.2 UNSUITABLE USE

The machine should be used to cut metallic materials exclusively and light alloys as shown on chapter SUITABLE USE. Any other use is absolutely forbidden.

- It is forbidden to use the machine **SIMULTANEOUSLY** employing more operators than those shown on chapter **CLASSIFICATION OF THE MACHINE OPERATORS**.
- It is forbidden to employ unskilled not trained operators.
- It is forbidden to load and discharge any stock material when the machine is running.
- It is forbidden to install and use the machine open-air by atmospheric agents.
- It is forbidden to install and use the machine by explosive conditions.
- It is forbidden to use the machine if the stock material or parts of it are likely to be projected outside the working area (area 1 fig. 1-6) causing some danger depending on material shape, positioning of the material on the machine and temperature.
- The machine is not designed to work on inflammable materials.

The machine is not according to Directive ATEX 94/9/CE and it is not suitable to run in explosive atmosphere or products generating any explosive atmosphere. The manufacturer does not authorize in any way the installation nor the use in such explosive environment. According to Directive 94/9/CE art. 1 the meaning of:

Explosive Atmosphere

Mix, in atmospheric conditions, of air and inflammable parts as gas, vapors, mist or dusts in which, after the primer, the combustion spreads with unburned mix.

Partial Explosive Atmosphere

Atmosphere which is likely to transform itself into atmospheric explosive because of local and operative conditions.

6.4.3 **CLAUSE of MANUFACTURER'S SAFEGUARD**

The manufacturer is not to be held responsible in case of accident to people or objects when the following facts occur:

- Voltage or pressure supply other than the one prescribed.
- Unsuitable use of the machine by untrained operators.

- Use contrary to the local or country laws.
- Lack of prescribed maintenance.
- Modification or intervention non authorized.
- Use of non original or non specific parts for the model at hand.
- Inobservance complete or partial to the instructions.
- Extraordinary events.

6.5 GENERAL ADVISES on SAFETY and PREVENTION

Non-observance to the following advises or modification to safety devices will raise the manufacturer from any responsibility in case of accident, injury to workers or damages and malfunctioning of the machine.

- **The machine working area (area 1 fig. 1-6) is a dangerous area to anyone who enters it becoming “exposed” to the risk. For safety purposes, it is forbidden to access the machine working area while the machine is running, in stand-by or at stop for any reason except the emergency stop by the pushing of the emergency push-button. Danger of serious injuries.**
- **The access to the machine is admitted while the machine is at stop and voltage supply disconnected.**
- The manufacturer, where possible, has managed to eliminate or reduce any danger to a minimum for the operator’s safety. Remaining risks on the machine have been reported at chapter OTHER RISKS.
- For the machine to be used properly and safely, it should be used with roller tracks supporting the stock material. This advise is compulsory.
- The SIMULTANEOUS use of the machine is admitted to the number of operators as prescribed at the chapter CLASSIFICATION OF THE MACHINE OPERATORS.
- The customer is bound to charge the use of the machine to qualified operators only, trained and in perfect psycho-physical conditions.
- The customer is bound to take any action to avoid the machine access to non authorized people.
- The customer is bound to inform properly his own operator about present safety prescriptions. To this purpose, he will take steps to let anyone involved in the use of the machine know about the PRESCRIPTIONS of CURRENT SAFETY REGULATIONS.
- The customer should inform the manufacturer in case of machine faults or malfunctions of the safety devices or any suspect of possible danger.
- The operator should fully observe the instructions contained in this document and the general safety regulations in European Countries and any national law about safety at work.
- The operator should wear personal protection devices according to the safety regulations in the European Countries and any national law about safety at work; moreover, he is bound to observe the prescriptions contained in this manual (see chapter PERSONAL PROTECTION DEVICES).
- The operator should observe all the dangerous signs attached to the machine.
- The operator should not take any personal decision about operations or interventions which do not regard his own competence.
- The operator is bound to inform his manager about any problem or dangerous occurrence.
- The operator should be trained by qualified teachers only.
- The machine has been designed and built according to the state of the technique and the safety regulations and offers a safe use. The machine has been tested with standard equipment only; any other part from other make or modifications may change the features of the machine and affect the safe functioning. The manufacturer deny any responsibility for any damage which could occur by the use of non original parts or non authorized modifications.

- The machine should be used for the purpose which it has been designed for (see chapter SUITABLE USE AND USUITABLE USE).
- It is forbidden to eliminate and/or remove the guards and the devices installed on the machine.
- The safety signs attached to the machine should not be eliminated or made unreadable.

7 GUARDS, PROTECTION DEVICES and SIGNS

- On the machine, with the purpose to eliminate and/or reduce the risks coming from mobile elements, the manufacturer has installed stationary protections, mobile interlocked guards and adjustable guards which restrict the access to dangerous areas (machine working area – 1 fig. 1-6).
- For the machine to work all the protection devices should be active and guards closed.
- As prescribed by paragraph 1.5.1 Annexure I of Machine Directive, the electric equipment is according to the safety standard by the Low Voltage 2014/35/UE; however, the evaluation of the conformity regarding the danger generated by the voltage supply is contemplated by the Machine Directive itself; consequently the machine is not certified to the directive Low Voltage Control.

7.1 GUARDS and PROTECTION DEVICES

- a) N. 1 Stationary Guard (1 fig. 1-7) on the fixed blade-guide block. The guard avoids the contact with the blade as it enters the blade-guide; also, it prevents access to the area in which the brush is located. The guard is made of steel plate press-bended and welded and it is mounted with screws to the blade-guide block. The resistance of the guard is suitable to the vibrations generated the normal use of the machine and maintenance works.
- b) N. 1 Stationary Guard (2 fig. 2-7) on the mobile blade-guide block. The guard avoids the contact with the blade as it enters the blade-guide; also, it prevents access to the area in which the brush is located. The guard is made of steel plate press-bended and welded and it is mounted with screws to the blade-guide block. The resistance of the guard is suitable to the vibrations generated the normal use of the machine and maintenance works.
- c) N. 1 Interlocked Mobile Guard (3 fig. 1-7) sawframe cover. The guard prevents the access to the blade and both flywheels. The Cover is electrically connected to a interlock switch (4 fig. 1-7), which stops the machine if the cover is open. The closure of the cover does not start the machine automatically, but it is necessary to press the button <READY> (5 fig. 1-7) on the control panel. The cover is made of steel plate which is assembled to the sawframe by means of two hinges; the closure is provided by screw plastic knobs.
- d) N. 1 Emergency Push-Button in red on yellow label <EMERGENCY> (6 fig. 1-7), located on the control panel. When pressed, the button stops the machine instantaneously as it cuts off the electric supply to all motors. To start again, you need to release the push-button <EMERGENCY> and press the button <READY> (5 fig. 1-7).
- e) The connection Plug allows to cut off the electric supply to the machine safely.
- f) The Electric Box (7 fig. 1-7) of the machine is IP 54 protected and contains all the power electric components having dangerous voltage. The cover is closed by screws.

- g) The electric installation makes sure the protection against electric shock, direct and indirect contacts as prescribed by the regulation EN 60204-1; also, it has been tested successfully to the examinations provided by paragraph. 18 of the regulation.
- h) The protection of the electric circuit against short-circuit is guaranteed by a set of fuses and ground connection; in case of motor overload, a thermal relay and a thermal probe are provided.
- i) In case of chute of electric supply, you need to press the button <READY> (5 fig. 1-7) to get the voltage to the machine when the electric supply is available.
- j) The control circuit is 24 Volt and the control components are IP 54 protected.

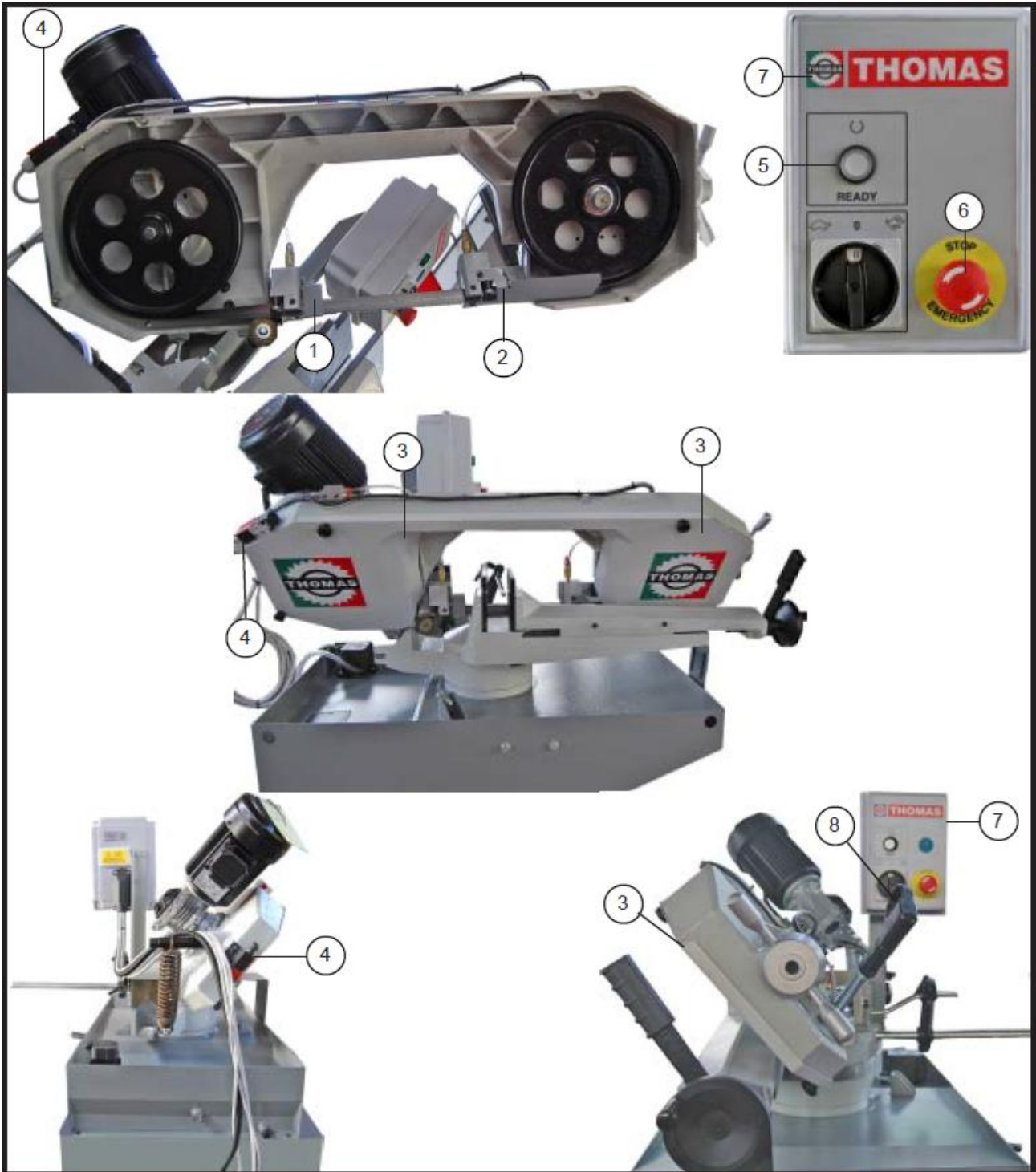

Fig. 1-7

7.2 SAFETY SIGNS ATTACHED TO THE MACHINE

Labels applied to the machine.

- 1) Danger : arms crushing.
- 2) Danger : hands cutting.
- 3) Danger : electric shock.
- 4) Attention: do not obstruct coolant liquid top drain hole.

- 5) Forbidden : maintenance/lubrication while parts in motion.
- 6) Forbidden : removal of safety devices.
- 7) Obligation : wear protection gloves.
- 8) Obligation : wear acoustic protection devices.
- 9) Obligation : wear protection glasses.
- 10) Obligation : safety devices check-up .
- 11) Obligation : user's manual reading.
- 12) Obligation : electric ground connection.

8 REMAINING RISKS

- Remaining risks are coming from those dangers which were not possible to eliminate while designing the machine and additional protection devices.
- The machine shows some spots where other risks are found; these were not possible to eliminate completely because of some technical reasons or in case the operator fails to observe the safety prescriptions given by the manufacturer.
- Remaining risks are basically bound to the fact that the blade and other mobile parts of the machine are not possible to isolate completely or they are partially isolated.
- Control place is on the ground and outside the dangerous areas. Working places (loading and discharge of stock material) are close to the dangerous areas.

DANGER

- Before accessing the electric box, cut off the electric power by switch off the main switch.
- In case of problems during the machine operation or danger, the operator should first stop the machine by pressing the emergency push-button.
- Only after the machine has been completely stopped, it is possible to access dangerous areas without any risk.
- It is forbidden to access dangerous areas which are listed in the following chapter while the machine is electric energized and/or running; remaining risks are there and whoever access them is to be considered as "exposed".

8.1 SPOTS or DANGEROUS AREAS ON THE MACHINE

Machine areas showing remaining risks are the following (fig. 1-8):

- 1) Zona A - Vice Area.
- 2) Zona B - Area of Loading and Discharging on roller tracks (if provided).
- 3) Zona C - Area between Vice and Sawframe Support.
- 4) Zona D - Blade running area – blade and exposed part of the blade.
- 5) Zona E – Blade clearing Brush.
- 6) Zona F – Electric Motor area.
- 7) Zona G – Discharge area.
- 8) Zona H - The complete machine.

The list below shows some danger and remaining risks on the machine with the identification of dangerous areas in which some activities are associated with dangerous situations.

As far as the area "I" is concerned (the complete machine), the remaining risk refers to the noise and vibrations which are to be evaluated when the machine is running.

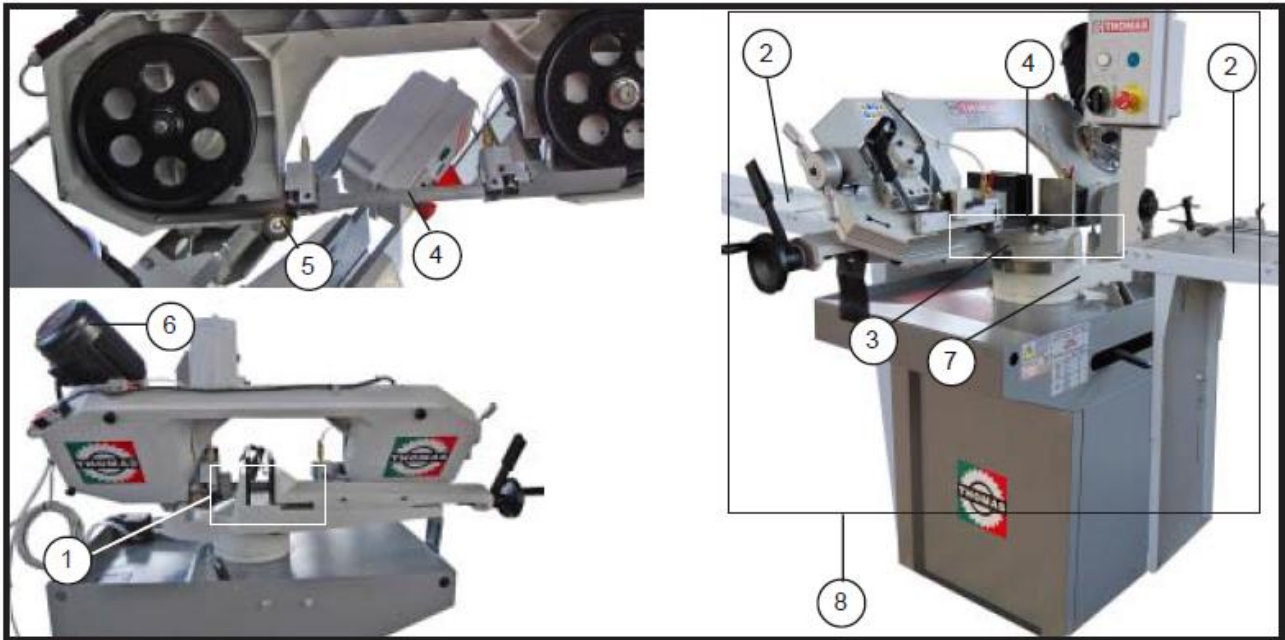

Fig. 1-8

DANGEROUS AREA “A” (Vice)

1.3 – Mechanic Danger – Approach of a mobile element to a stationary part

Possible Consequences

Danger: hands crushing as the vice locks the stock material – between mobile and fixed parts of the vice on its movement to lock the stock material – between the material in motion and the vice.

Operative Cycle

Laying the stock material in the vice - material moves in the vice.

Employed

Operator

Dangerous Event

Vice locking – material moving during vice closing – material fall after the cut is completed.

Risk Frequency

Risk is there all the time during machine using.

Operator’s Risk

Serious injury for hands.

Considerations on Remaining Risk

On this machine the vice closes by operator’s hand manually. The risk is there just in case of lack of attention or operator’s carelessness, or lack of observance to the safety prescriptions and/or in case the machine is ran by more than one operator.

DANGEROUS AREA “B” (Roller Tracks on loading side and discharge – if any)

1.3 – Mechanic Danger – Approach of a mobile element to a stationary part

Possible Consequences

Danger: hands crushing as the stock material moves on the rollers.

Operative Cycle

Stock material moving on the roller tracks.

Employed

Operator

Dangerous Event

Loading or Discharge of the stock material on the roller tracks – Stock material moving on the roller tracks.

Risk Frequency

Risk is there all the time during the use of the roller tracks.

Operator’s Risk

Serious injury for hands.

Considerations on Remaining Risk

Roller Tracks are not motorized and the movement of the stock material is manual and is effected by the operator directly. The risk is there just in case of lack of attention or operator’s carelessness, or lack of observance to the safety prescriptions and/or in case the machine is ran by more than one operator.

DANGEROUS AREA “C” (Between Vice, Working Table and Sawframe)

1.3 – Mechanic danger – Approach of a mobile element to a stationary part

Possible Consequences

Danger: Arm Crushing between vice, sawframe support and sawframe during its downfeed.

Operative Cycle

Running Tests – use of the machine.

Employed

Operator

Dangerous Event

Sawframe downfeed to cut the material.

Risk Frequency

Risk is there all the time during the machine.

Operator’s Risk

Arms injury.

Considerations on Remaining Risk

On this machine the sawframe downfeed is manually pull down by the operator. The risk is there just in case of lack of attention or operator’s carelessness, or lack of observance to the safety prescriptions and/or in case the machine is ran by more than one operator.

DANGEROUS AREA “D” (Zona di lavoro del nastro – nastro e parte esposta del nastro)

1.4 – Mechanic Danger – Cutting Parts

1.6 – Mechanic Danger – Fall or Object projection

1.11 – Mechanic Danger – Mobile Elements

3.3 – Thermal Danger – Objects at high or low temperature of Stock Material

▪ Possible Consequences

- Danger : hands or fingers amputation between the blade (at stop or running) the working table, between the blade (at stop or running) and the vice jaws.
- Danger : cut of hands/fingers shearing by the blade in motion.
- Danger : dragging by the blade in motion.
- Danger : perforation of hands/fingers during blade handling.

- Danger : projection of blade parts or material being cut: in case of blade breakage or chips / swarf projection from the stock material.
- Danger : hands or fingers contact with hot parts caused by blade stock material overheating.

Operative Cycle

Running Test – Machine use – Adjustment – Maintenance.

Employed

Operator

Dangerous Event

Sawframe downfeed – Blade running during functioning test – Blade running during material cutting – Blade Handling during replacement.

Risk Frequency

Risk is there all the time during Loading/Discharge of stock material, use, cleaning, adjustment, maintenance, machine repair, blade replacement.

Operator’s Risk

- Serious Injury to hands and Fingers.
- Hands burn.

▪ **Considerations on Remaining Risk**

Dangerous area is accessible as far as the blade is supposed to cut the material.

The risk is there just in case of lack of attention or operator’s carelessness, or lack of observance to the safety prescriptions and/or in case the machine is ran by more than one operator.

- a) **It is forbidden to approach the hands to blade and vice, between blade vice jaws, between blade and sawframe support.**
- b) **It is forbidden to touch the blade during running.**
- c) **It is forbidden to insert the hands between the blade and the stationary parts or the blade clearing brush.**
- d) **Maintenance or repair works should be carried out with the machine at stop only and electric isolated from mains. During Loading/Discharge of stock material the operator should wear protection gloves and pay utmost attention.**
- e) **The operator during Loading/Discharge of stock material, use, adjustment/maintenance/repair of the machine should:**
 - **Adjust the movable blade-guard according to the dimensions of the stock material;**
 - **Execute the Material Loading/Discharge and machine adjustment having previously switched off the machine and pressed the emergency push-button;**
 - **Stay away at safe distance off the dangerous area during machine operation;**
 - **Carry out maintenance and repair works having previously switched off the machine and pressed the emergency push-button;**
 - **Use protection gloves to load / discharge the stock material and blade handling.**

DANGEROUS AREA “E” (Blade cleaning Brush)

1.13 - Mechanic Danger – rough surface

1.14 – Mechanic Danger – cutting edges

▪ **Possible Consequences**

- **Danger: hands abrasion in case of contact with the steel brush as it turns.**
- **perforation of hands/fingers during brush handling.**

Operative Cycle

Machine use – maintenance.

Employed

Operator

Dangerous event

Contact with the steel brush.

Risk Frequency

Risk is there all the time during the machine use – cleaning or brush replacement.

Operator’s Risk

Hands injury.

▪ **Considerations on Remaining Risk**

The risk is there just in case of lack of attention or operator’s carelessness, or lack of observance to the safety prescriptions.

- Carry out maintenance and repair works having previously switched off the machine and pressed the emergency push-button;
- The operator during cleaning or brush replacing should pay utmost attention and wear protection gloves.

DANGEROUS AREA “F” (Electric Motor)

3.3 – Thermal Danger – Objects at high or low temperature of Stock Material

▪ **Possible Consequences**

Danger : contact with high temperature parts.

Operative Cycle

Test – machine use.

Employed

Operator

Dangerous event

When running the motor and gear-box can heat up to 80° C.

Risk Frequency

Risk is there all the time during machine use and a few minutes after the machine stop.

Operator’s Risk

Hands burn.

▪ **Considerations on Remaining Risk**

- The risk is there just in case of lack of attention or operator’s carelessness, or lack of observance to the safety prescriptions. The operator should wear protection gloves as he gets in contact with the electric motor and the gear-box.

DANGEROUS AREA “G” (Discharge of cut material)

1.4 - Mechanic Danger – cutting edges

1.6 – Mechanic Danger – Fall or part Projection

▪ **Possible Consequences**

- Danger: hands abrasion in case of contact with the swarf/chips or material.
- Danger: hands or feet crushing in case of material falling off the working table.

▪ **Operative Cycle**

Material moving – machine use.

Employed

Operator

▪ **Dangerous event**

- The stock material may have burrs or cutting edges before and after the cut.

- After the cut is completed, particularly if stock material is a large one, material may fall off the machine or roller tracks.

▪ **Risk Frequency**

Risk is there all the time during machine use.

Operator's Risk

Lesioni anche gravi alle mani e ai piedi.

▪ **Considerations on Remaining Risk**

The risk is there just in case of lack of attention or operator's carelessness, or lack of observance to the safety prescriptions. The operator should keep at safe distance away from the danferous area during machine use and wear protection gloves and shoes.

DANGEROUS AREA "H" (complete machine)

4.4 – Noise – Working Process

▪ **Possible Consequences**

Auditive problem, stress and fatigue because of noise during cutting.

▪ **Operative Cycle**

Machine use.

Employed

Operator

▪ **Dangerous event**

Acoustic emission during cutting.

Risk Frequency

Risk is there all the time during machine use.

Operator's Risk

Acoustic injury.

▪ **Considerations on Remaining Risk**

The risk is there just in case of lack of observance to the safety prescriptions: the operator should wear acoustic protection such as ears plugs.

8.2 PERSONAL PROTECTION DEVICES

The operator or anyone who is going to run the machine even temporarily, should wear the following personal protection devices (DPI):

Obligation: wear protection gloves

during moving, placement, loading/discharging of stock material, cleaning, maintenance, de-installation and scrap.

Obligation: wear Work blue overalls

during machine use.

Obligation: wear protection glasses

during machine use.

Obligation: wear protection shoes

During moving, use, maintenance and scrap.

Obligation: wear protection helmet

During moving and scrap.

Obligation: wear acoustic protection plugs

During machine use.

9 MOVING

9.1 GENERAL ADVISES

INOBSERVANCE TO THESE ADVISES, WILL RAISE THE MANUFACTURER FROM ANY RESPONSIBILITY IN CASE of ACCIDENT, DAMAGE or MACHINE MALFUNCTIONING.

- The user and his colleagues are bound to read the following advises in advance.
- Before moving and/or transport the machine, electric disconnect the machine.
- Moving operations should be carried out from qualified workers only and in perfect psycho-physical conditions.
- It is forbidden to use lifting equipment which are not suitable for the weight and dimensions of the machine. The use of unsuitable lifting devices may cause serious injury to involved workers accident and damages to the machine or nearby objects.
- Lifting equipment should be according to the current safety regulations.
- Avoid more workers to be involved in the operation simultaneously and without coordination which may cause risk.
- Check dimensions and machine weight.
- It is forbidden to climb on the machine, stay and/or walk under it during its moving.
- It is forbidden entering the moving area to anyone not involved on the operations.
- Everyone should keep distance to avoid hitting by the machine or its part.
- Before commencing the operation, it is necessary to identify and check the moving area including the area in which the truck is expected to move and the installation area as well with the purpose to avoid dangerous obstacles.
- Hook the machine to the lifting point only as shown by the following pictures.
- Use lifting straps if their labels clearly showing capacities from their manufacturer. Inspect the straps before use: do not use them if damaged, cut or worn out or anything which could lead to collapse during the lifting. Do not twist or knot the straps and observe the advises given by their manufacturer. Same advises are to follow in case of chains instead straps use.
- Lifting the machine one should pay utmost attention to the load swinging sideways.

Operators:

n. 1 mechanic worker + n. 1 operator in charge with the lifting devices.

Personal protection devices:

protection gloves + shoes + helmet.

9.2 DELIVERY OF THE MACHINE

- Upon delivery, check the machine in all its parts: in case of damages during transportation, these are to be notified to the manufacturer immediately and within the day after. Deviations from the delivery note should be notified too.
- As long as the machine is not installed, store the machine indoor, avoid humid and too high or low temperatures.

- High Temperature alterations or minus 0° C for more than 72 hours may cause damages to electric equipment.

9.3 MOVING THE MACHINE WITH FORK LIFT TRUCK

Machine Status:

Machine ready for moving.

Operators:

n. 1 mechanic worker + n. 1 operator in charge with the lifting devices.

Personal protection devices:

protection gloves + shoes + helmet.

9.3.1 MOVING THE MACHINE WITH FORK LIFT TRUCK

- a) Insert the forks of the truck into the pallet (fig. 1-9). Secure the machine with straps around the base of the vice.
- b) Lift the machine as low as possible and avoid any shake or brusque movement.
- c) Set the machine on the working installation place, gently rest it down to the floor and avoid any bumping.

9.3.2 MOVING THE MACHINE WITH OVERHEAD CRANE

- a) Insert the straps into the special holes (fig. 2-9) located at the four corners of the machine bench.
- b) Hook the straps to the crane.
- c) Lift the machine as low as possible and avoid any shake or brusque movement.
- d) Set the machine on the working installation place, gently rest it down to the floor and avoid any bumping.

9.4 TRANSPORTATION OF THE MACHINE

Make sure the truck floor should be perfectly even to avoid load moving during transportation.

- a) The machine should be set on the truck floor vertically, secured down the floor with fixtures and straps.
- b) Insert the straps under the vice base (fig. 3-9).
- c) Make sure that the straps are not going to bend or crack any part of the machine.

Once the transportation has been completed before releasing the machine from the straps, make sure that it did not move during transportation and that its position on the truck floor is not dangerous.

Unload the machine from the truck as follows:

- a) Release the machine from the straps and fixtures which held the machine during transportation.
- b) Lift and discharge the machine from the truck floor as prescribed by chapter 9.3 MOVING.

In case the machine needs to be moved to a different location, the transportation should be carried out reversing the instructions given for the upload of the machine.

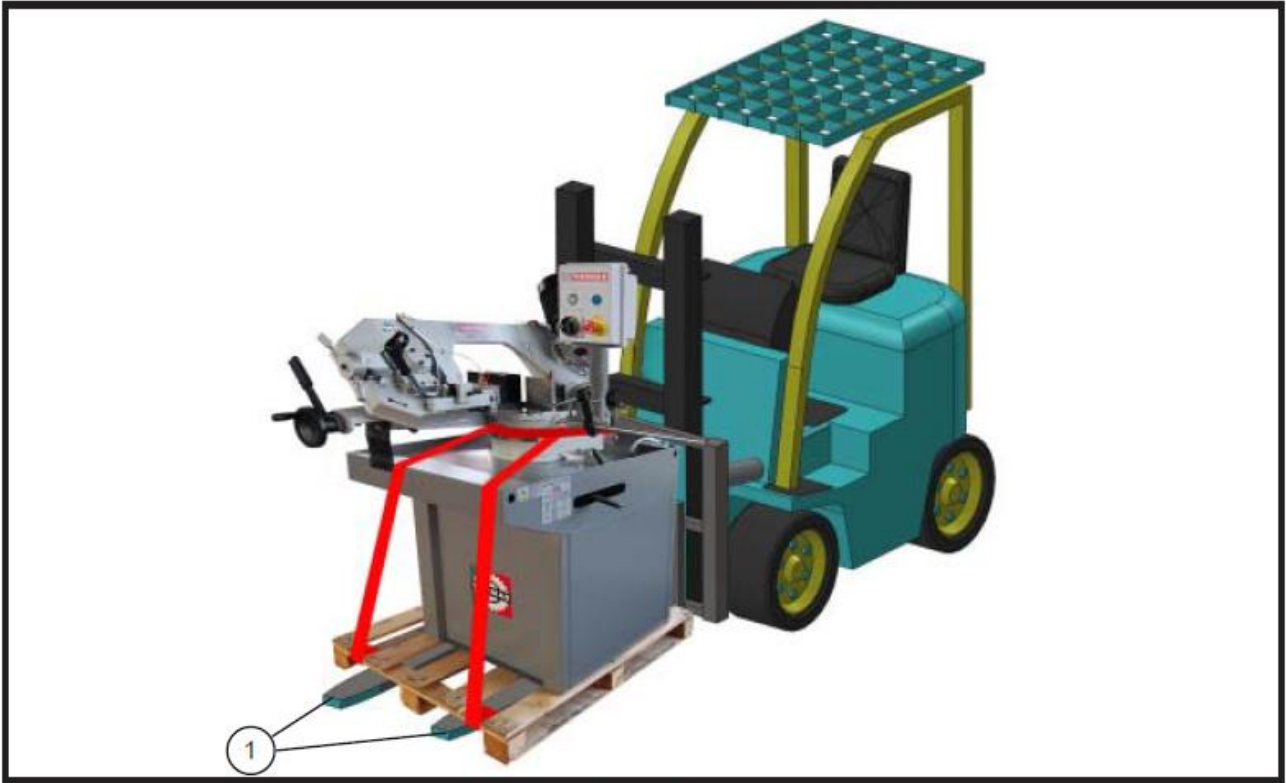

Fig. 1-9

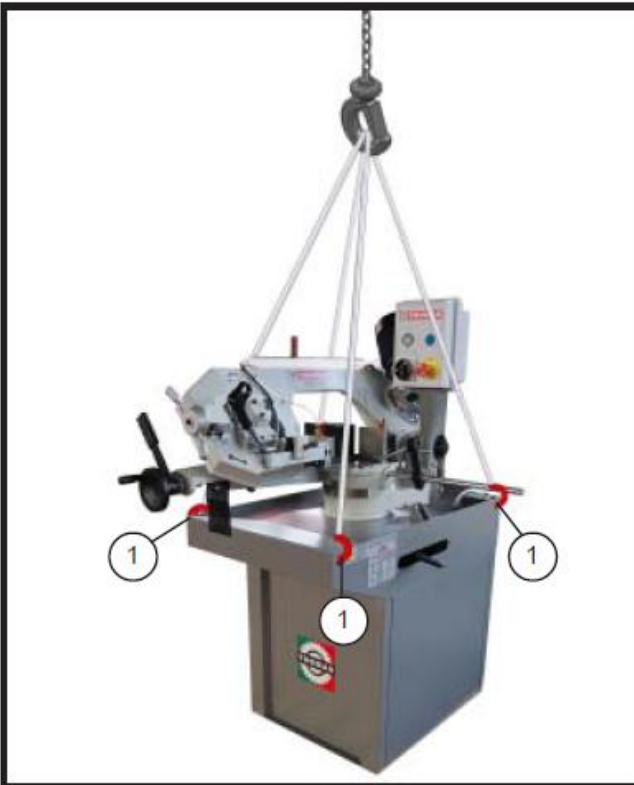

Fig. 2-9

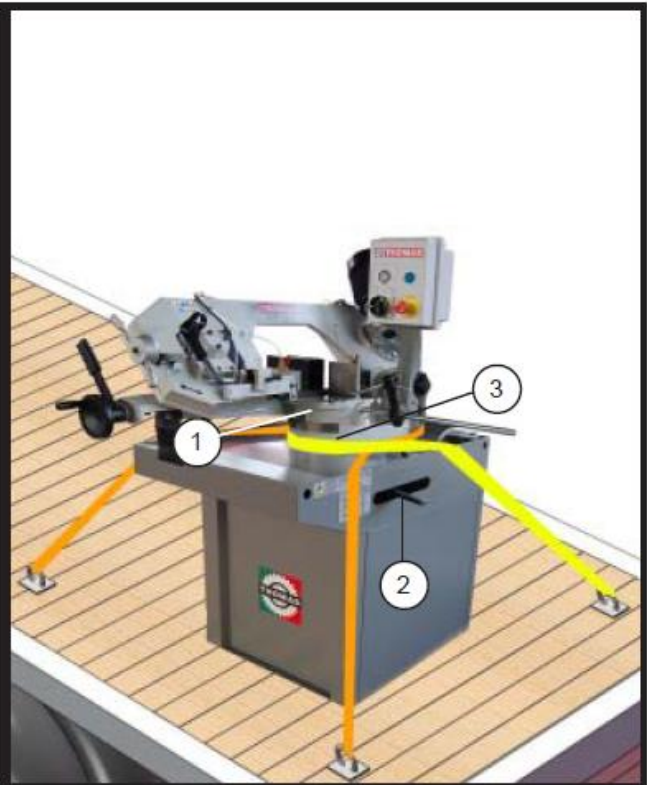

Fig. 3-9

10 INSTALLATION OF THE MACHINE

10.1 GENERAL ADVISE

INOBSERVANCE TO THESE ADVISES, WILL RAISE THE MANUFACTURER FROM ANY RESPONSIBILITY IN CASE of ACCIDENT, DAMAGE or MACHINE MALFUNCTIONING.

- The installation of the machine should be carried out by qualified technicians only and in perfect psycho-physical conditions.
- During the installation of the machine make sure you are not going to damage the machine nor causing injury to anyone around.
- The working place of the machine should be on a solid base and sufficient room around the machine should be provided for a proper and safe use.
- Check machine technical data complying with requested features.
- Check installation area and make sure that nearby “dangerous areas” are not involved.

10.2 AMBIENCE CONDITIONS

Admitted values for the proper use of the machine and its electric equipment :

- temperature: from 5 to 40 ° C average not over 35° C through 24 hours;
- humidity: between 30% and 95% without condensation;
- height: max 1000 m above sea level.

10.3 PREPARATION OF INSTALLATION PLACE

- The customer should prepare the installation place according to the installation drawing (fig. 1-10).
- The user should provide electric supply socket at handy spots allowing easy electric connection. Provide free floor space 1000 mm alla around the machine.
- The machine should be set up on a floor having 1000 kg/m² capacity, without any depression and built according to the regulations suitable for the current activity.
- The machine should be set up according to:
 - a) The dimensions of the machine,
 - b) The presence of other machines, walls or other obstacles,
 - c) The room needed to install accessories such as roller tracks (if any) for loading and unloading of the stock material,
 - d) The room needed for the load and unload of the stock material,
 - e) The room to guarantee proper use and maintenance in safe conditions.

ATTENTION

The luminosity of the working place according to the current regulation (at least 200 lux in general and at least 500 lux on the control and work place); this responsibility is at the charge of the user.

The installation drawing (fig. 1-10) shows the dimensions, the anchorage spots and spot for the electric connection to the mains.

Three-phase power supply

- | | | |
|---------------------------------|----|---------------------|
| ▪ Installed electric power..... | kW | 1,1 |
| ▪ Voltage..... | V | 400 trifase +/- 10% |
| ▪ Frequency | Hz | 50 +/- 1% |

Single-phase power supply

- | | | |
|---------------------------------|----|----------------------|
| ▪ Installed electric power..... | kW | 1,1 |
| ▪ Voltage..... | V | 230 monofase +/- 10% |
| ▪ Frequency | Hz | 50 +/- 1% |

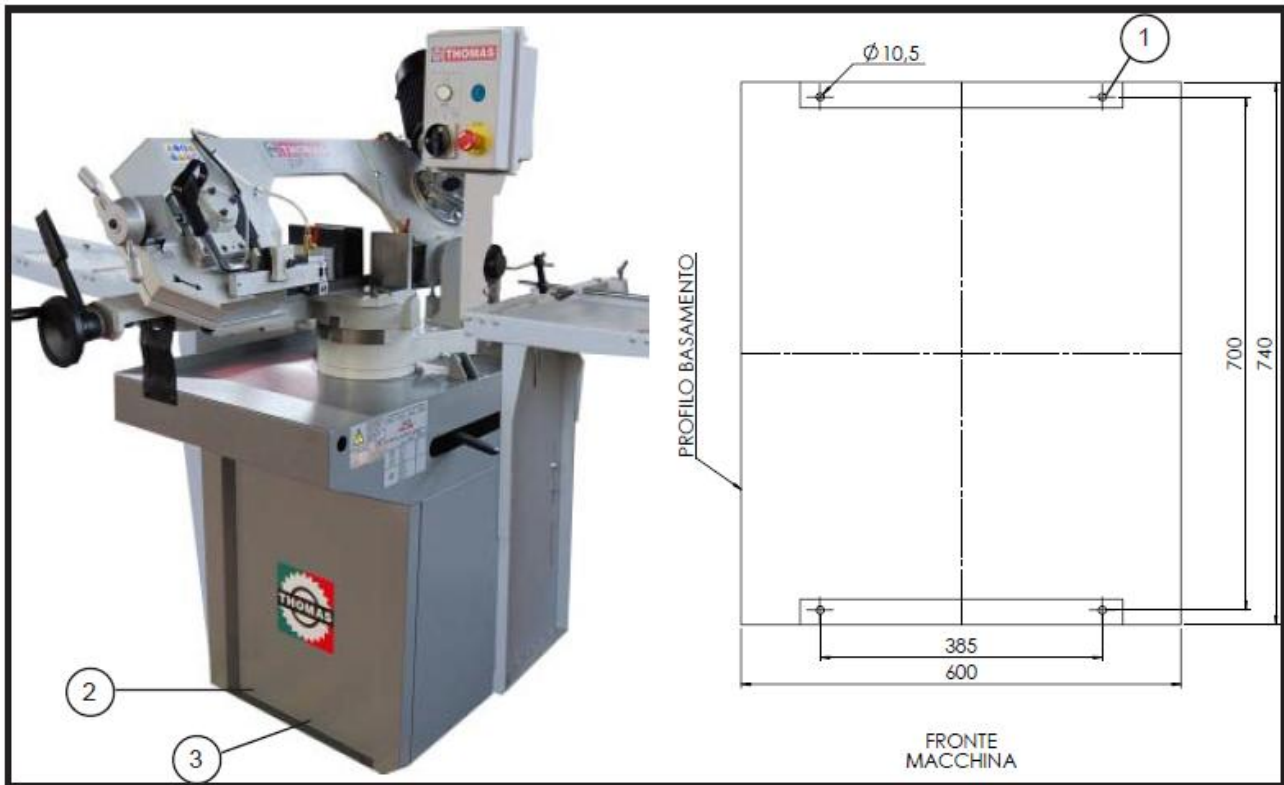

Fig. 1-10

10.4 ANCHORAGE OF THE MACHINE

Machine Status:

Machine set up on the installation place.

Operators:

n. 1 mechanic worker

- a) Referring to the drawing (fig. 1-10), provide fastening and guys to be anchored on the floor.
- b) The machine should be set so as the holes on the machine base (1 fig. 1-10) coincide with the guys down to the floor.
- c) Insert the screws (2 fig. 1-10) through the holes on the machine base and tight them partially.
- d) Place a level gauge on the working table of the machine and adjust the base to get a precise balance. Just in case, insert some pieces of metal plates between the base and the floor (3 fig. 1-10).
- e) Once the balance is perfectly set, tight the screws (1 fig. 1-10) so the machine is anchored down to the floor securely.

10.5 ELECTRIC CONNECTION TO THE MACHINE

- The electric equipment of the machine should be suitable for 400 Volt and frequency 50 Hz. Make sure the voltage on the machine label and control box label, matches the voltage from the mains power supply.

- The manufacturer delivers the machine without any current plug: the user should connect a proper plug bearing in mind that the electric circuit of the machine is a three-phase 5 cables with neutral; the combination socket-plug should be certified for 16A.
- The user should install a proper electric connection to the local protection circuit including a magneto-thermal switch and power cut-off switch so it should be possible to isolate the machine completely.
- Before making any electric connection, the user should make sure that:
 - a) The local electric system is equipped with a regular ground connection according to current electric regulations;
 - b) The local voltage and frequency should correspond to the voltage and frequency of the machine;
 - c) The local distribution electric system should be provided with fuse valves and magneto-thermal switch properly set.
 - d) Proper machine functioning admits max. $\pm 5\%$ tolerance on electric fluctuations with regards to the nominal power value.

Machine status:

Machine anchored to installation place.

Operators:

n. 1 electrician.

- a) Switch off the local electric board.
- b) For the connection to the local electric board and the power station, install one 16 A three-phase 5 cables plug with neutral bearing in mind the type of the provided socket.
- c) If the cable supplied with the machine should not be suitable to the installation requirements, replace it with one of correct section to the power in use (see label placed on the electric board), local temperature, conditions and length of the cable.
- d) Wire the three power cables R=L1, S=L2, T=L3 and the ground wire PE=GND (fig. 2-10).

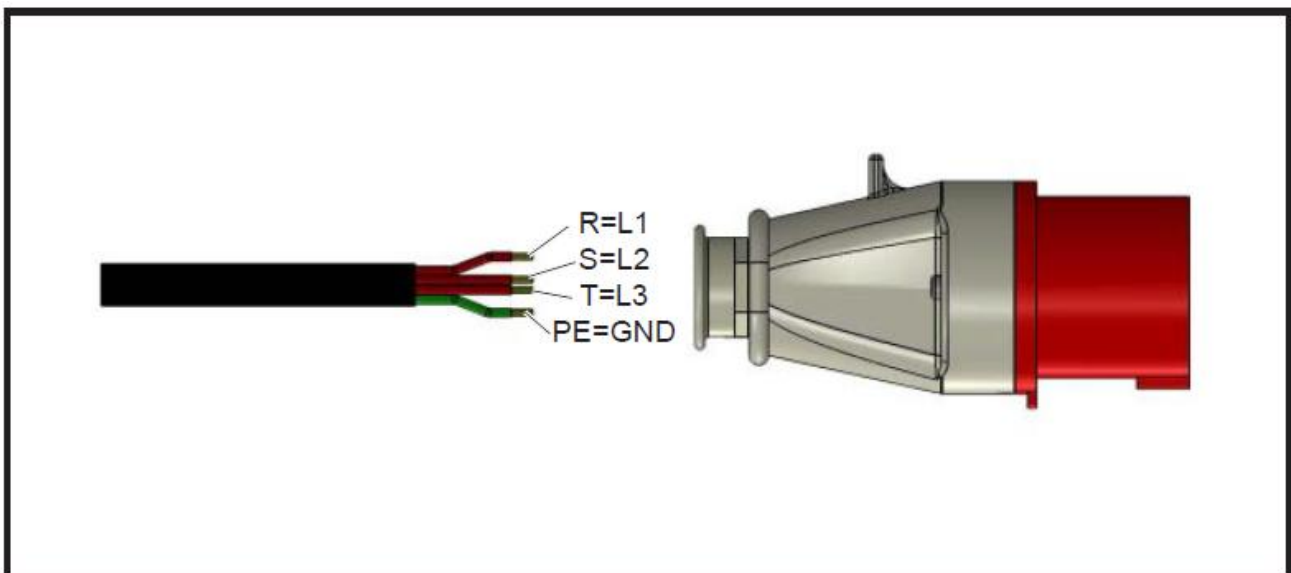

Fig. 2-10

10.6 MOUNTING PARTS AND ACCESSORIES SEPARATELY DELIVERED

Machine status:

Machine installed.

Operator:

N. 1 mechanic worker

- Mount bar stop Rod (1 fig. 3-10).
- Mount and align the stock material support (2 fig. 3-10) to the left side of the base.
- Mount the splash guard (3 fig. 3-10) to the left side of the base.
- Clean the machine if any dirty particles accumulate during transportation, moving and installation. Use a brush and clean towels.
- Clean and dry accurately every single part, covered or painted, using soft, clean and dry towels. Refer to the chapter. MACHINE CLEANING.

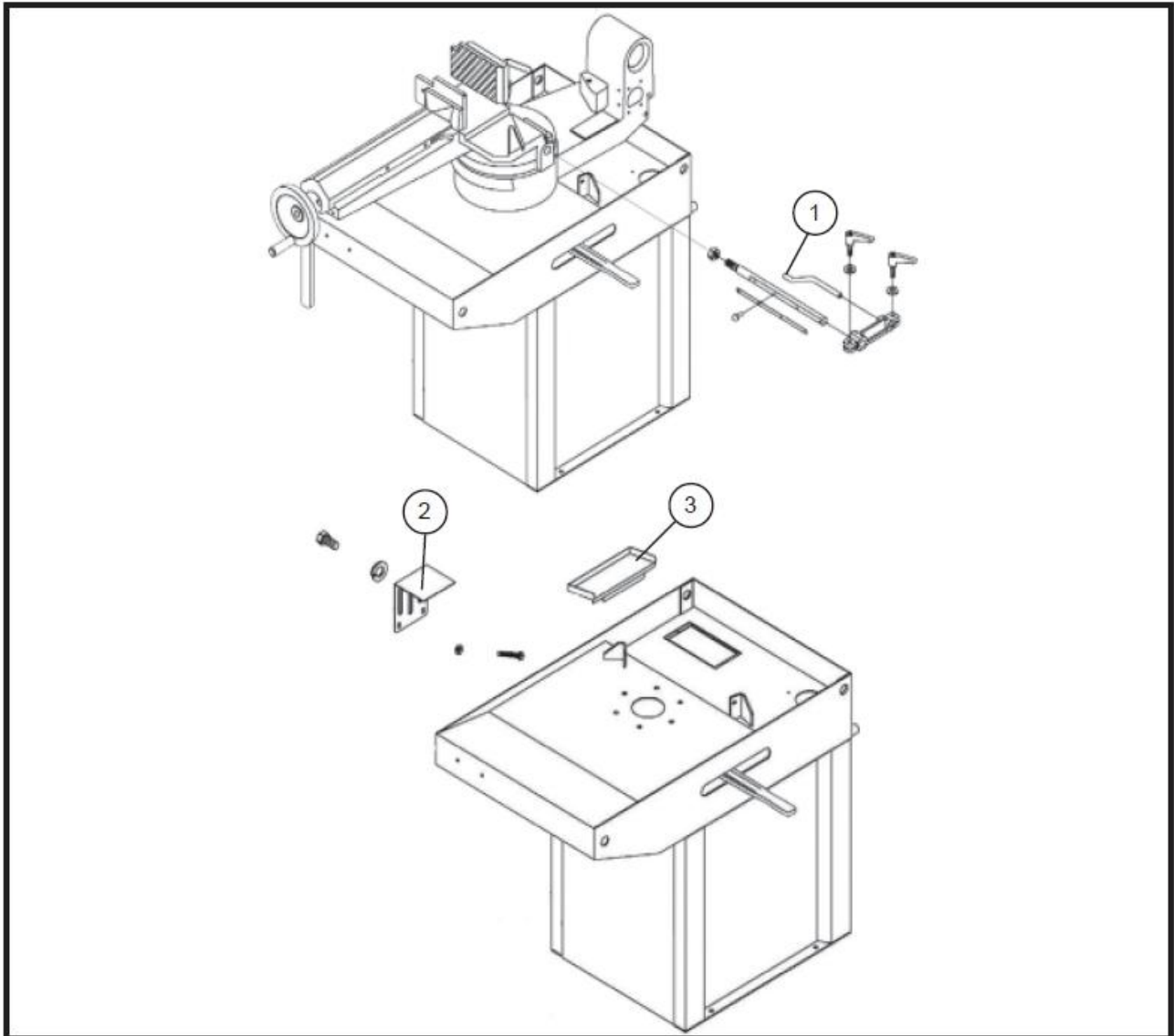

Fig. 3-10

11 USE OF THE MACHINE

11.1 GENERAL ADVISES

- **The machine working area (area 1 fig. 1-6) is a dangerous area and anybody accessing the area is to be considered "exposed" to risk. Serious risk injury.**
- **Access to the working area with machine at stop and electric plug disconnected.**
- The manufacturer, where possible, has managed to eliminate or reduce any danger to a minimum for the operator's safety. Remaining risks on the machine have been reported at chapter OTHER RISKS..
- For the machine to be used properly and safely, it should be used with roller tracks supporting the stock material. This advise is compulsory.
- the risk evaluation and the connection to the machine are to user's charge as well as caution and safety devices to avoid or reduce the relevant risks.
- The SIMULTANEOUS use of the machine is admitted to the number of operators as prescribed at the chapter CLASSIFICATION OF THE MACHINE OPERATORS.
- Loading and Discharge of stock material onto and off the roller tracks would require a certain number of workers who may be employed by the user according to the available lifting devices and dimensions/weight of the stock material.
- Before starting the machine, make sure that the operator is aware about the positions and the functioning of the controls. He should be able to carry out all the operations described in this manual making sure that he fully understood the safety regulations and their application.
- The machine should be ran by qualified workers only, trained and in perfect psycho-physical conditions.
- Before starting the machine, ALWAYS check the following:
 - a) All the safety devices should be active, all the stationary guards should be properly installed and the mobile guards closed;
 - b) All the controls should be perfectly working;
 - c) Clear the machine from tools or stranger objects;
 - d) The floor around the machine should be clear and clean.
- The operator should wear working cloth without any loose or long sleeves which may cause pinching or pulling in the machine dangerous area. Do not wear too large gloves, bracelets, chains or any other object which may cause pinching or pulling. Hold tight long hair.
- During the use of the machine make sure that nobody stand near the machine, particularly in the area of loading and unloading the stock material see chapter. DESCRIPTION OF THE WORKING PLACE.
- When using the machine the operator should wear personal protection devices (DPI) such as:
 - Protection gloves (during load and unloading of stock material)
 - Work blue overalls
 - Protection Shoes
 - Protection Glasses
 - Acoustic Protection
- The sawframe, at rest in top position, should have the blade at stop.
- Execute one operation at a time and do not engage the hands with objects at the same time. Keep the hands cleaned.

- When the machine is working, parts in motion should not be touched in any way, guards should not be removed, cleaning or maintenance operations should not take place. Do not remove swarf material

ATTENTION - PROHIBITION

- a) It is forbidden to work with materials which are not contemplated by the manufacturer.
- b) It is forbidden to disconnect or mishandle the push-button controlling the motor (trigger switch - 1 fig. 1-11) controlling blade start.
- c) It is forbidden to use any parts (for ex. metal plates) to avoid docking of the stock material in the vice and hold the material by hand during the cutting.
- d) It is forbidden to introduce the stock material from the right hand side to the left with respect to the machine front.

ATTENTION – OBLIGATION

- a) It is compulsory to leave clear the part of the blade which is engaged in the cut only. To do so, adjust the mobile blade-guide as close as possible to the stock material.
- b) It is compulsory, before making any intervention on the machine whatever it may be, to switch off the power removing the plug (2 fig. 1-11) from the socket.
- c) It is compulsory, in case of danger or before making any intervention, to stop the machine by pressing the red emergency push-button (3 fig. 1-11).
- d) It is compulsory, at the end of each working shift, to switch off the power removing the plug (2 fig. 1-11) from the socket.

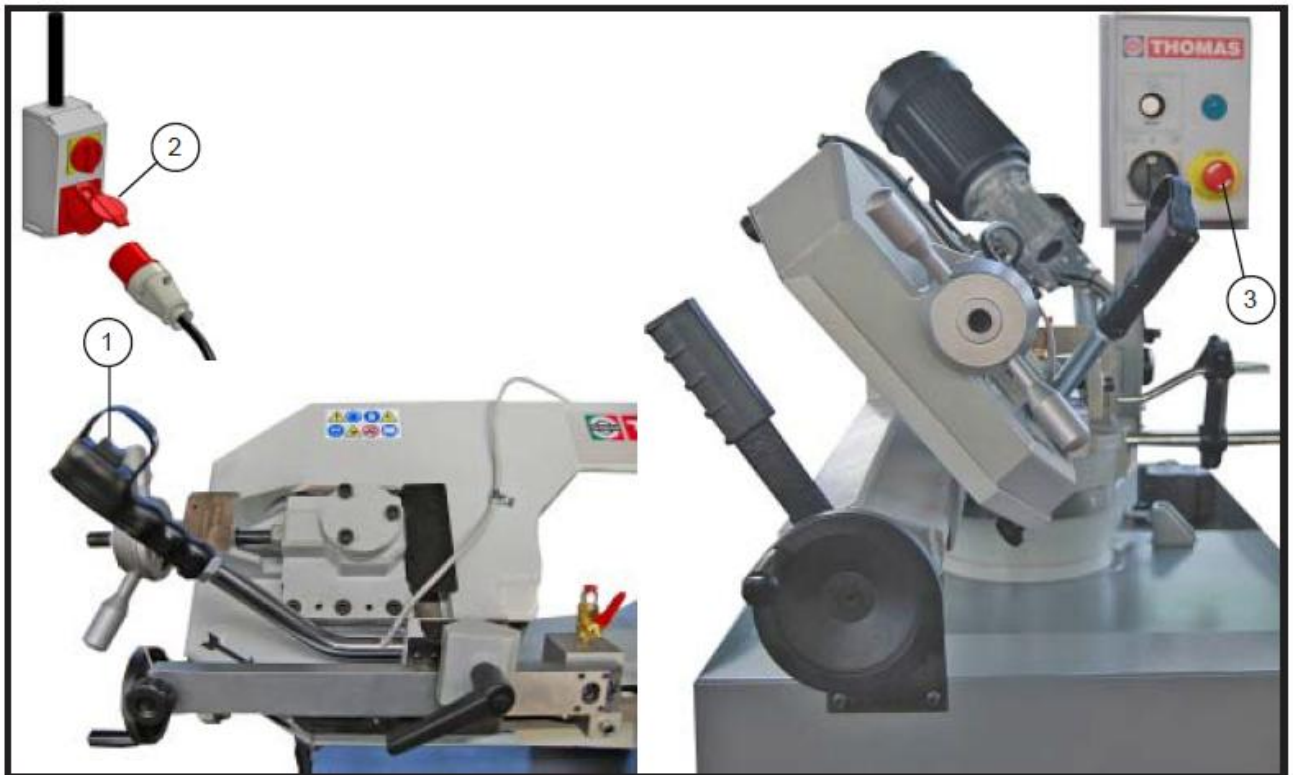

Fig. 1-11

11.2 CHECK EFFICIENCY OF SAFETY DEVICES

Machine status:

Machine energized (stand-by) ready to start.

Operator:

N. 1 operator.

ATTENTION

Every time, before starting the machine, it is compulsory to check the safety devices as follows:

11.2.1 EMERGENCY PUSH-BUTTON.

- Check the efficiency of the emergency push-button (1 fig. 2-11) located on the control panel.
- The machine energized and ready to start (push-button <READY> lit up - 2 fig. 2-11), but not working (blade at stop) press the emergency push-button:
the luminous button <READY> should turn out and if you press the trigger switch (3 fig. 2-11) the blade should not start.
- To start again the machine you need to release the emergency push-button and press the luminous push-button <READY> (2 fig. 2-11).

ATTENTION

If the machine does not stop, a qualified electrician should check the electric installation and make the emergency push-button perfectly working.



Fig. 2-11

11.2.2 INTERLOCKING ON THE SAWFRAME COVER

- Make sure that the switch (2 fig. 3-11) located on the sawframe cover (1 fig. 3-1) is perfectly working.
- The machine energized and ready to start (luminous push-button <READY> lit up - 2 fig. 2-11) but not working (blade at stop) slightly open the sawframe cover:

luminous push-button <READY> should turn out and and if you press the trigger switch (3 fig. 2-11) the blade should not start.

To start again the machine you need to close the sawframe cover and press the button <READY> (2 fig. 2-11).

ATTENTION

If the machine does not stop, a qualified electrician should check the electric installation and make the emergency push-button perfectly working.



Fig. 3-11

11.3 ADJUSTMENTS ON THE MACHINE

Machine status:

Machine completely switched off (electric plug removed from the socket).

Operator:

N. 1 operator

Personal protection devices:

- Protection gloves
- Work blue overalls

11.3.1 BLADE TENSION

- Blade tension is obtained by turning the hand wheel (1 fig. 4-11) clockwise.

- Turn the hand wheel till the index gets to the green area (2 fig. 4-11), or against the mechanical stop (3 fig. 4-11).

NOTE

If the machine remains unused, it is advised to loosen the blade tension.

Use blades with dimensions corresponding to those shown in this manual.

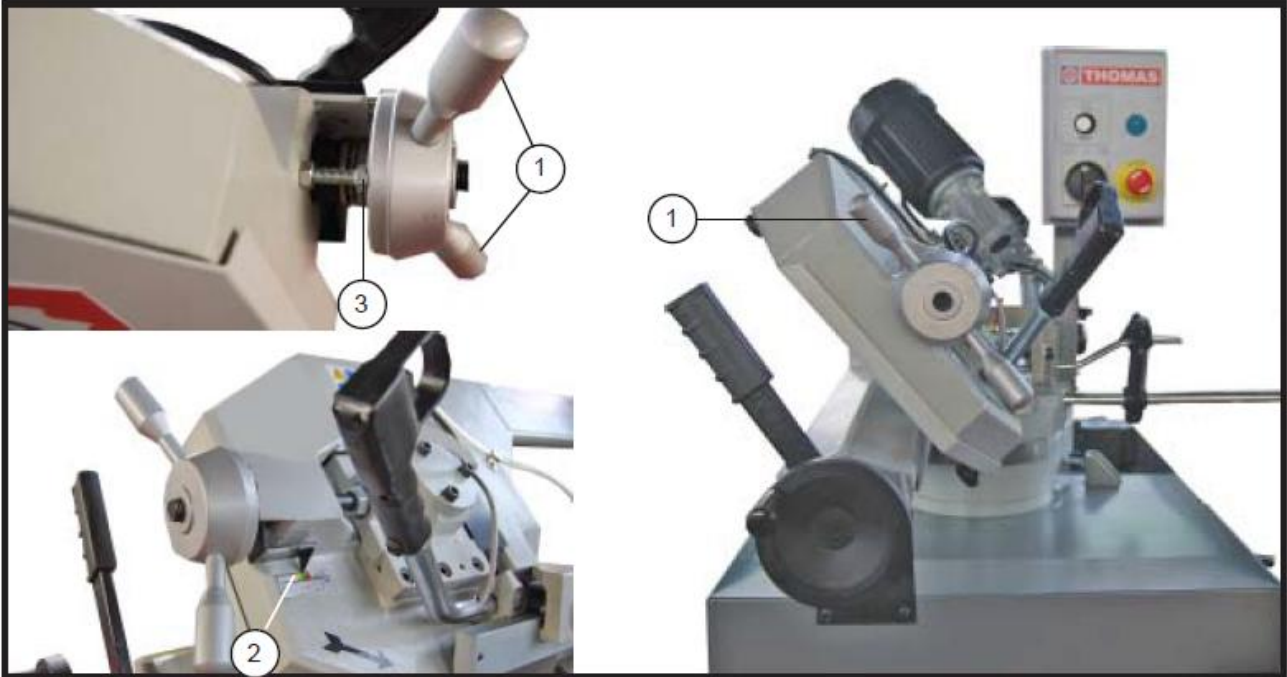

Fig. 4-11

11.3.2 ADJUSTMENT OF BLADE-GUIDE BLOCKS

The blade runs through a set of carbide pads which are adjusted by the manufacturer according to the thickness of the blade as shown on fig. 6-11.

In case of blade replacement, make sure that the thickness of the blade is 0.9 mm for the carbide pads have been adjusted by the manufacturer.

Carbide pads are expected to be replaced after worn out. The following instructions show how to replace and adjust the new pads :

The following tools are needed for this operation:

- 1 = Hex key 5,
- 2 = T Hex key 4,
- 3 = Key 13,
- 4 = T Hex key 5,
- 5 = Screw driver,
- 6 = T Hex key 3,
- 7 = Key 11.

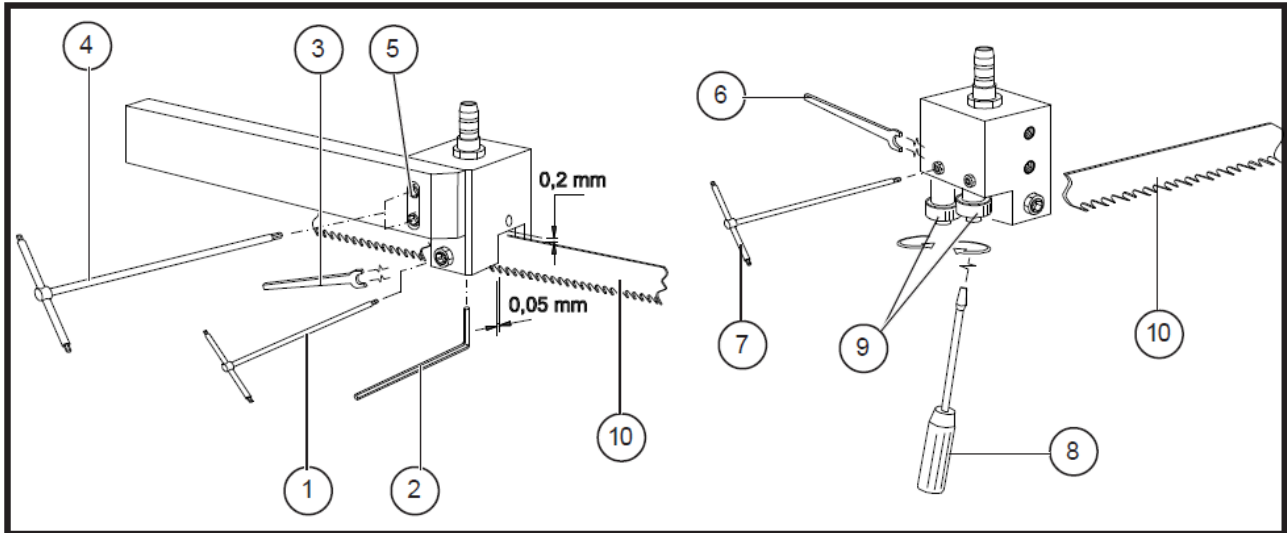

Fig. 6-11

NOTE

If you need to replace the blade, refer to chapter BLADE REPLACEMENT.

- a) Raise the sawframe to the top position.
- b) First adjust the mobile blade-guide pad (1 fig. 6-11) use the key 2 and leave a gap 0.05 mm between the pad and the blade.
- c) Once so adjusted, tight the screw (2 fig. 6-11) with the key 1 and the nut (3 fig. 6-11) with the key 3.
- d) With the key 4, adjust the blade-guide block (4 fig. 6-11) leaving a gap of 0.2 mm between the back of the blade and the top part of the stationary pad.
- e) Once so adjusted, tight the screws (5 fig. 6-11) with the key 4 making sure that the block stands perpendicular with respect to the blade.
- f) With the keys 7 and 6 release the screws (6 fig. 6-11) as shown on the drawing and using a screwdriver 5 rotate the pins (7 fig. 6-11) till the bearings (8 fig. 6-11) rest against the blade.

NOTE Bearings should rest on the blade just providing a light pressure against it; thus, the blade should be gently twisted before getting through the carbide pads.

- g) Once so adjusted, tight screws and nuts firmly.

ATTENTION

- Proper adjustment of blade-guide carbide pads will guarantee perfect cutting performance and long life blade.
- Keep blade-guides always clean and lubricated making sure the coolant liquid flow through the holes on the blade-guide blocks.

11.3.3 VICE ADJUSTMENT**Movement of the vice**

- The vice is located LEFT of the blade. This type of vice is stationary.

Vice locking

Quick lock Lever (2 fig. 7-11) can be pulled to hold firmly the stock material in the vice; first approach the vice with the hand wheel (3 fig. 7-11) leaving 3 - 4 mm clear from the stock material.

Vice Gib

If after some time the vice becomes unstable, just tight the screws (4 fig. 7-11).

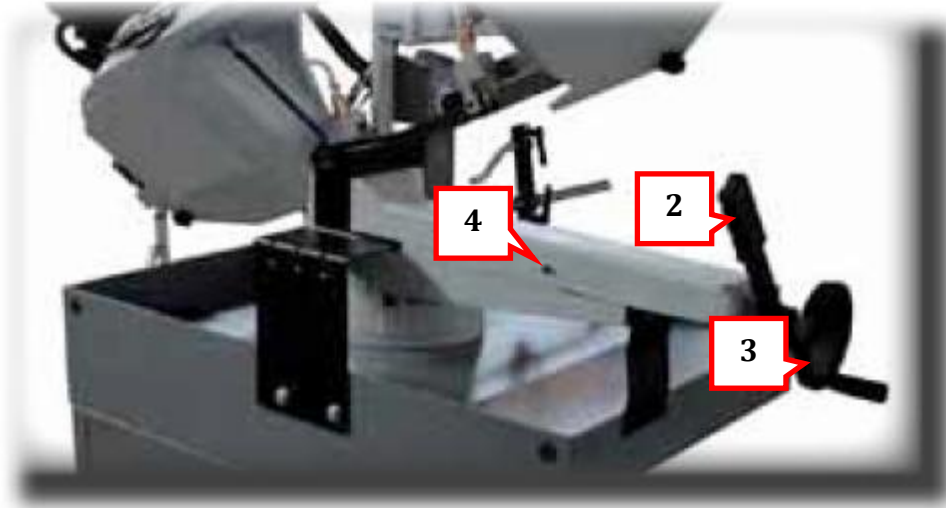

Fig. 7-11

11.3.4 ADJUSTMENT OF THE CUTTING ANGLE (MITRE)

Release the Lever (1 fig. 8-11) and turn the sawframe to the desired cutting angle with reference to special degree scale punched under the vice.

ATTENTION

Do not pull the Lever too tight !! Gently move the lever to lock and unlock position.

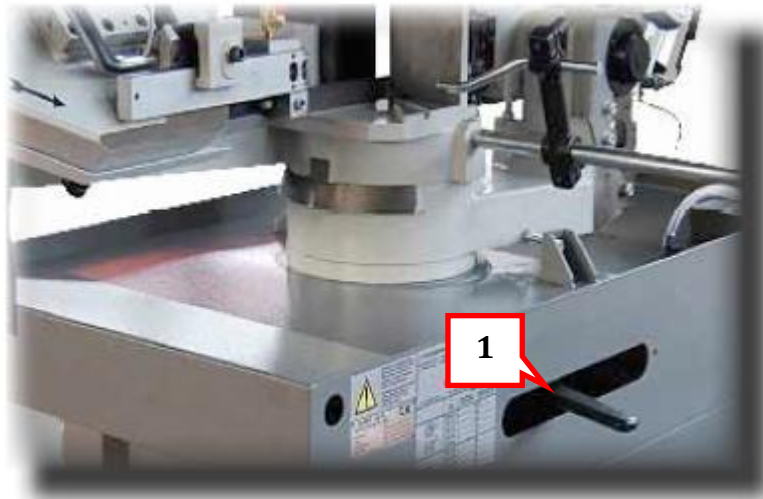

Fig. 8-11

11.3.5 BLADE REPLACEMENT

- a) Raise the sawframe to the top position.
- b) Release the blade tension by turning the hand wheel (1 fig. 9-11) anti-clockwise.
- c) Open the sawframe cover (2 fig. 9-11) by releasing the black plastic knobs (3 fig. 9-11).
- d) Remove the mobile blade-guide protection (4 fig. 9-11).
- e) Remove the blade off the flywheels (5 fig. 9-11) and blade-guide blocks (6 fig. 9-11).
- f) Mount the new blade first inserting it through the blade-guide carbide pads and then placing it onto the flywheels, making sure that the blade teeth direction is according to 7 fig. 9-11.
- g) Put the blade under tension by turning the hand wheel (1 fig. 9-11) clockwise and making sure that the blade perfectly seat on the flywheels.
- h) Mount the mobile blade-guide protection (4 fig. 9-11) and close the sawframe cover with the knobs (3 fig. 9-11). Doing so, the relevant interlock switch is activated, otherwise the machine could not start.

ATTENTION

Make sure you are going to mount blades with dimensions corresponding to those shown in this manual only.

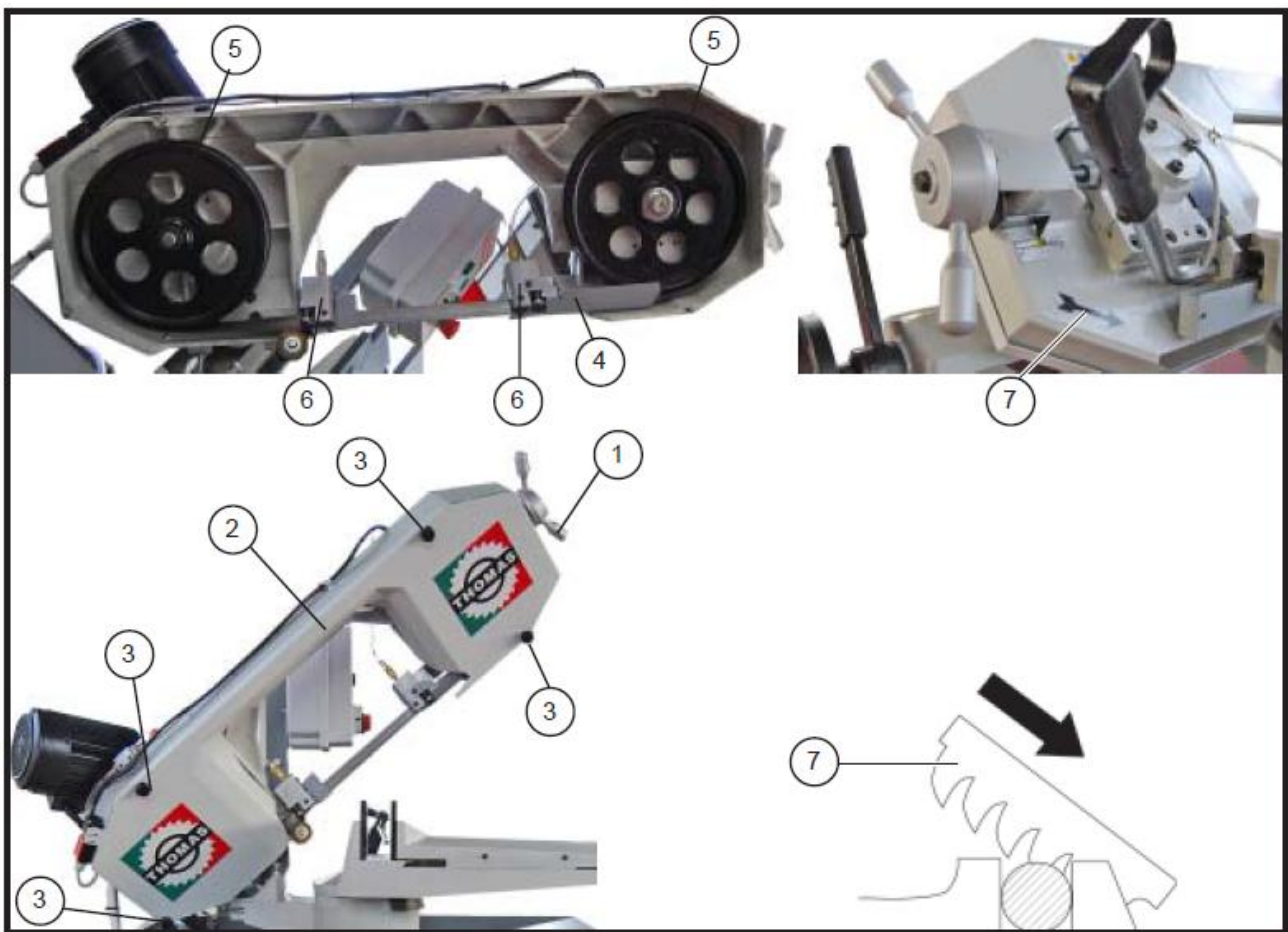

Fig. 9-11

11.4 START AND USE OF THE MACHINE

ADVISE

At the beginning of each working shift, before starting the machine, it is compulsory to check the safety devices (see chapter CHECK-UP OF SAFETY DEVICES EFFICIENCY).

Machine Status:

Machine ready for use.

Operators:

N. 1 operator

Personal safety protection:

- Protection gloves (during loading and discharging of the stock material)
- Work blue overalls
- Protection shoes
- Protection glasses
- Acoustic plugs

11.4.1 ADVISES FOR THE MACHINE USE

- Before starting any cutting operation, make sure that the stock material is firmly locked in the vice and supported at both ends.
- See table here below (fig. 10-11) showing some clamping methods on different profiles. Always make sure that the stock material is not too large for the machine cutting capacity.
- Make sure you are going to mount blades with dimensions corresponding to those shown in this manual only.
- If the blade should stuck in the material during the cutting, press emergency push-button immediately, switch off the machine, slowly open the vice by the hand wheel, remove the material and make sure that the blade or the teeth are not broken. In such a case, replace the blade.
- Check sawframe return spring.
- Before making any intervention or repair on the machine, ask your technical advisor on contact the manufacturer directly.

ATTENTION

Do not approach your hands to the cutting area.

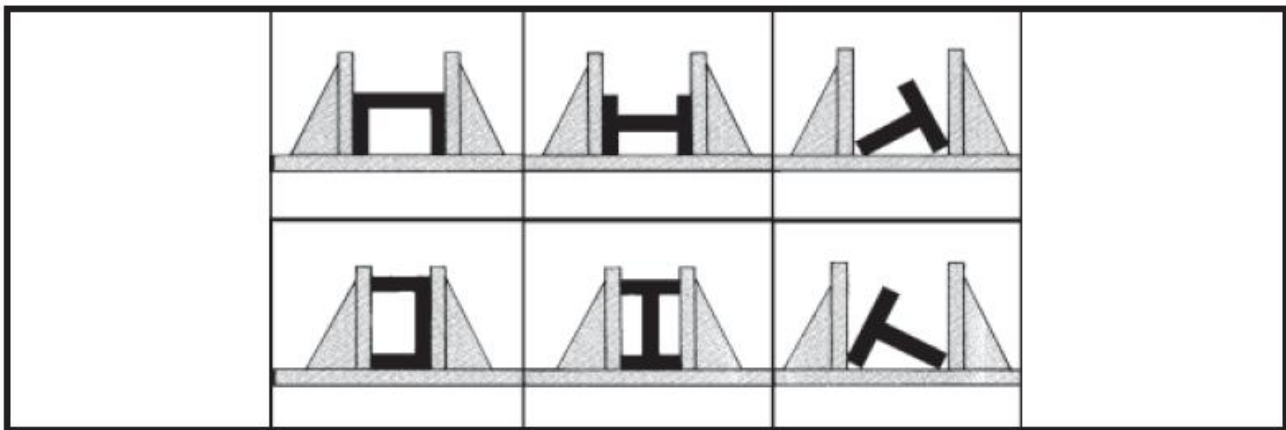

Fig. 10-11

11.4.2 WORKING CYCLE

Before using the machine, make sure that all preparation and adjustment of the machine have been completed. See chapter ADJUSTMENT OF THE MACHINE.

11.4.3 DESCRIPTION OF THE CUTTING CYCLE

- a) Vice close by hand wheel.
- b) Manual pull down of the sawframe and cut.
- c) Manual sawframe lifting.
- d) Vice opening by hand wheel.

11.4.4 CUTTING CYCLE

1. Bear in mind that CUTTING SPEED and BLADE TYPE, combined with a proper SAWFRAME DOWNFEED SPEED, are extremely important to get an accurate cut (see following chapter STOCK MATERIAL CLASSIFICATION AND BLADE SELECTION).
2. When a new blade is mounted, allow run-in time for the first cuts. Pull down the sawframe very slowly approximately twice the normal cutting time (see following chapter STOCK MATERIAL CLASSIFICATION AND BLADE SELECTION – BLADE RUN-IN).
3. Press the emergency push-button as soon as danger or malfunctioning show up.
4. Make sure the blade turn in the sense shown by the arrow attached to the machine sawframe (1 fig. 11-11).



Fig. 11-11

- a) Make sure that the emergency push-button (1 fig. 12-11) is released; if it is still engaged the machine will not start.
 - b) Turn the blade tension hand wheel (2 fig. 12-11) clockwise until the safety micro-switch button is pressed down. Select blade speed on the commutator (4 fig. 12-11):
 - position 1 = **32** m/min
 - position 2 = **64** m/min
 - c) Load the stock material and approach the vice jaw to 3 - 4 mm from the material to cut. Pull the quick lever (5 fig. 12-11) to lock the material to cut in the vice firmly.
 - d) Press the luminous push-button (6 fig. 12-11) to energize the machine.
5. Grab the lever (7 fig. 12-11) and press the trigger switch (8 fig. 12-11).: make sure that the blade turns in the sense shown by the arrow (1 fig. 11-11). If it does not, swap the cables from the power supply.
 - e) Open the coolant liquid taps (9 fig. 12-11) and make sure the liquid flows through the blade-guide blocks on the material to cut. Coolant liquid is an emulsion of water and 5% cutting oil.

ATTENTION

When you stop using the machine, let the sawframe raise to the top position and release blade tension by turning the hand wheel (2 fig. 12-11) anti-clockwise to avoid loss of blade flexibility.

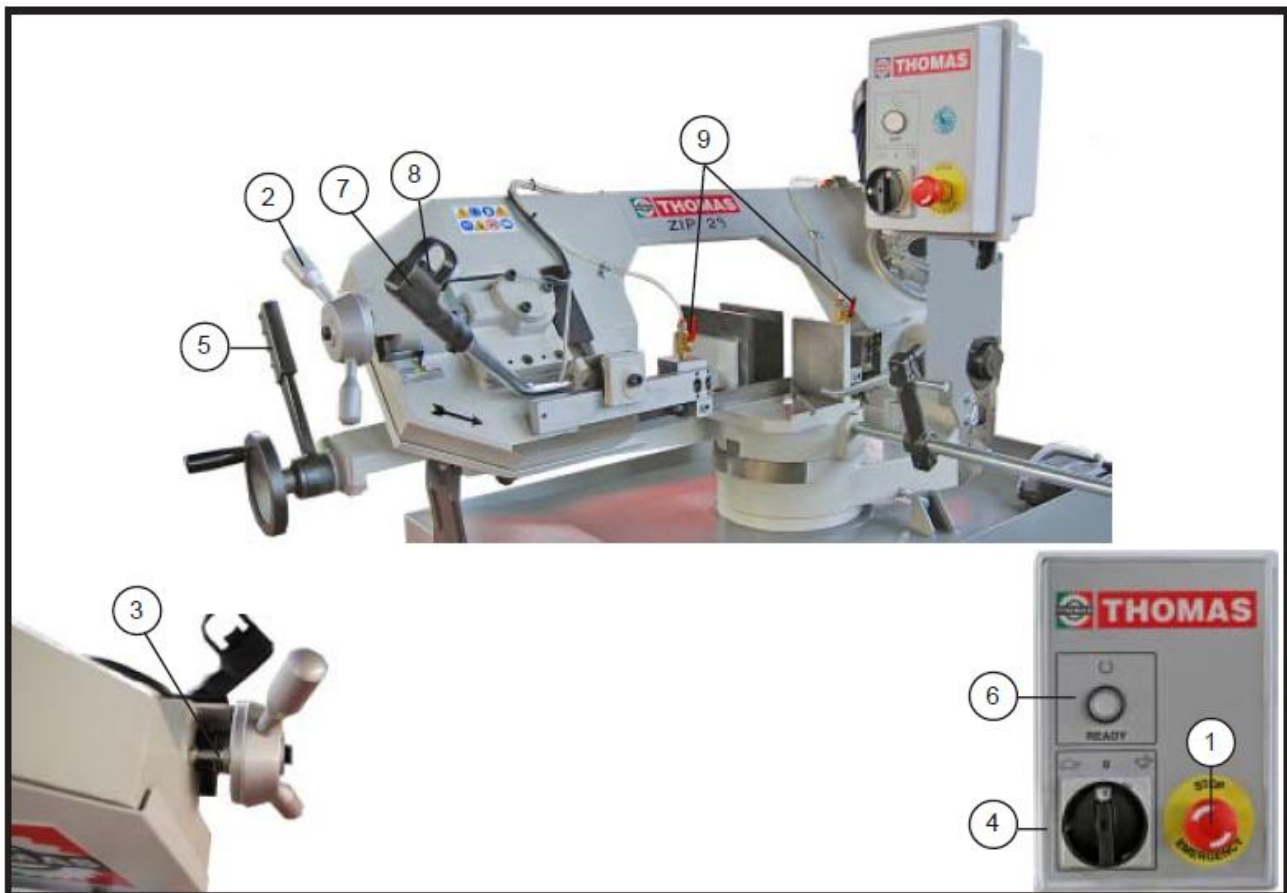

Fig. 12-11

11.4.5 CUTTING CYCLE with OPTION “HB” CONTROLLED SAWFRAME DOWNFEED

- Vice close by hand wheel.
 - Sawframe gravity downfeed hydraulic controlled and cut.
 - Manual sawframe lifting.
 - Vice opening by hand wheel.
1. The hydraulic regulator (1 fig. 13-11) controls the sawframe gravity downfeed speed. **The sawframe downfeed speed should be adjusted according to the section and hardness of the stock material bearing in mind that when cutting thick and hard material the downfeed speed should be slow. On the other hand, thin and light material can be sawn at a proportionally quicker downfeed speed rate.**
 2. The valve (2 fig. 13-11) to START or STOP the sawframe downfeed. The motor will stop automatically at the end of the cut as the limit micro-switch is pressed.
 3. Press the Button Start (1 fig. 14-11) on the control panel to Start blade rotation.
 4. For the preliminary operations refer to previous paragraph 11.4.4.

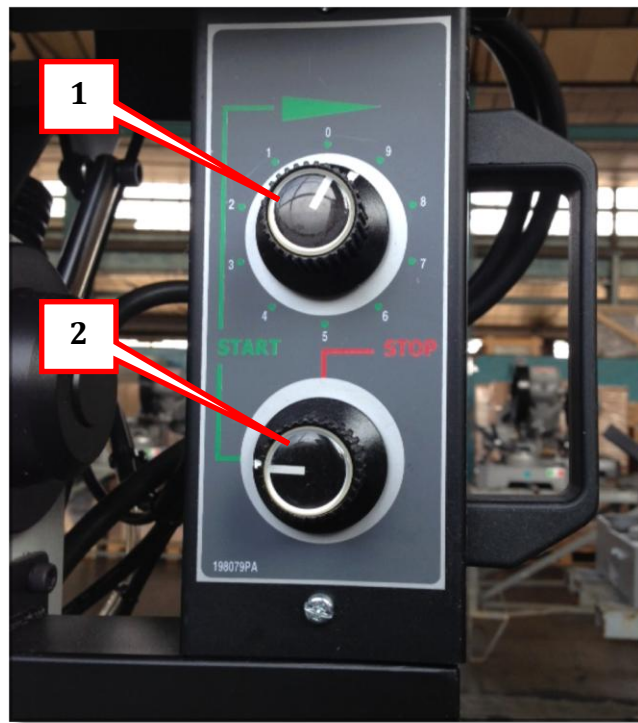

Fig. 13-11



Fig. 14-11

12 MAINTENANCE OF THE MACHINE

12.1 GENERAL ADVISES

Maintenance operations are classified in daily, weekly, monthly and biannual. Bear in mind that lack of maintenance determine a poor performance and a shorter machine life.

- All the cleaning and maintenance works are to be effected with the machine at stop and the power off except where otherwise indicated; the plug should therefore disconnected (1 fig. 1-12) and completely removed away from the socket.
- Operations effected with energized machine may cause serious injury even lethal.
- Maintenance operations should be effected by qualified operators only in good psycho-physical conditions.
- Before any maintenance operation, clean the machine accurately.
- During these operations, people not involved should keep at safety distance away from the machine.
- Observe maintenance agenda given by the manufacturer.
- Do not put any tool or any other object on the machine as they may fall causing injury or damages.
- If the safety devices need to be removed, remember to install them again before using the machine.
- Once the maintenance works are completed, before starting the machine, the technician in charge should make sure that the works are actually completed, the safety devices are active and the people not involved are not standing around the machine.
- For the machine cleaning observe the chapter. MACHINE CLEANING.
- Pay attention to the use of compressed air. This should not be directed to the skin nor to the eyes as it may cause serious injury.

- For all the works which may be dangerous for the eyes, wear protection glasses.
- During the maintenance of the machine, the operators should wear personal protection devices (DPI) such as :
 - Protection gloves
 - Protection shoes
 - Work blue overalls
- Before effecting any electric intervention, make sure that anyone can energize the machine showing proper signs.
- If it is needed to work by the energized machine to find out a trouble for example, this should be done by qualified electrician only and in possession of special tools.
- In case of danger, or accidental contacts switch off the machine and disconnect the plug.

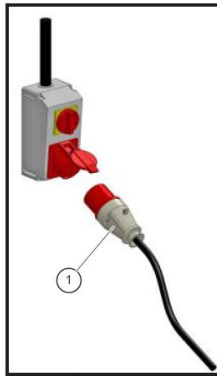

Fig. 1-12

12.2 REGULAR MAINTENANCE

Machine status:

Machine at stop and plug disconnected from the socket (1 fig. 1-12).

Operators:

N. 1 operator

Personal protection devices:

- Protection Gloves
- Work blue overalls
- Protection shoes



Fig. 2-12

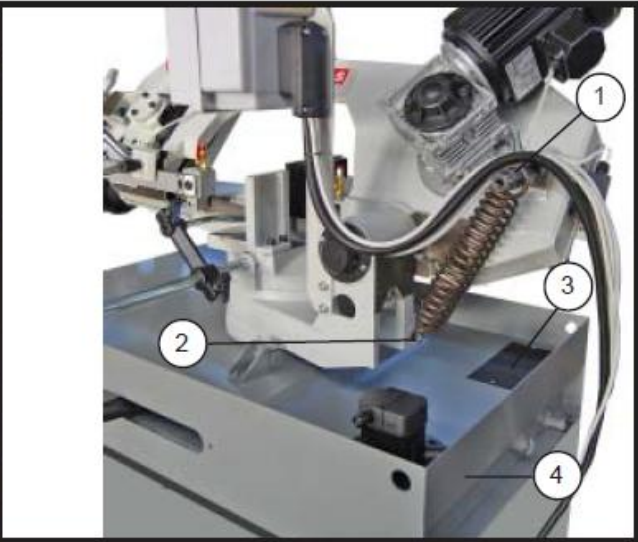

Fig. 3-12

12.2.1 BLADE CLEANING BRUSH

- Blade cleaning brush (1 fig. 2-12) is a very important device for the proper blade cleaning as the swarf should not stick to the blade teeth during the cutting operation.
- Periodically check the brush and possibly adjust it to touch lightly the blade teeth.

12.2.2 REPLACEMENT OF SAWFRAME RETURN SPRING

- During this operation a lifting device to hold the sawframe up should be provided (for example overhead crane).
- Remove the spring off the upper bar (1 fig. 3-12) and unhook from the lower tie rod (2 fig. 3-12).

NOTE

- Replacement of other components like gear-box, electro-pump and electric components should be effected by qualified operators only.
- As far as the worm screw gear-box is concerned, this a maintenance free component as its lubrication is guaranteed for life.

12.2.3 DAILY MAINTENANCE

- Remove the chips/swarf from the machine, clean the floor around the machine.
- Check drain plug (1 fig. 4-12) for the coolant liquid in excess.
- Refill coolant liquid in the tank (2 fig. 4-12).
- Check blade teeth wear.

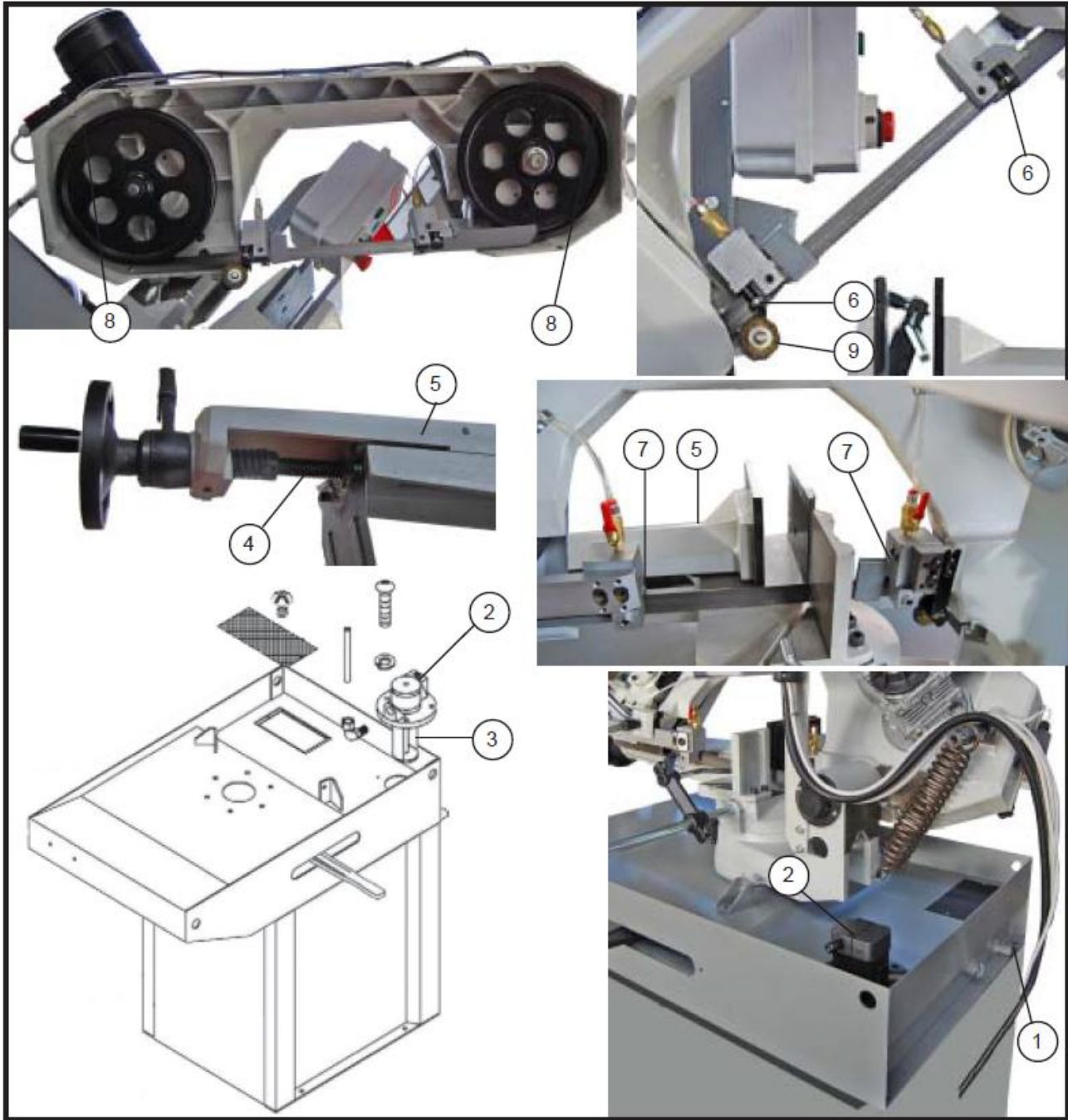

Fig. 4-12

12.2.4 WEEKLY MAINTENANCE

- Clean and remove the chips/swarf from the coolant liquid tank (1 fig. 4-12).
- Remove the electro-pump (2 fig. 4-12) from its housing, clean the draught filter (3 fig. 4-12).
- Clean and oil the vice screw (4 fig. 4-12) and the vice slide (4 fig. 4-12).
- Clean the blade-guide carbide pads with compressed air, in particular the bearings (6 fig. 4-12) and holes for the coolant liquid (7 fig. 4-12).
- Clean the sawframe internal part, the flywheels in particular the tracks where the blade run (8 fig. 4-12).
- Check wear of blade clearing brush.

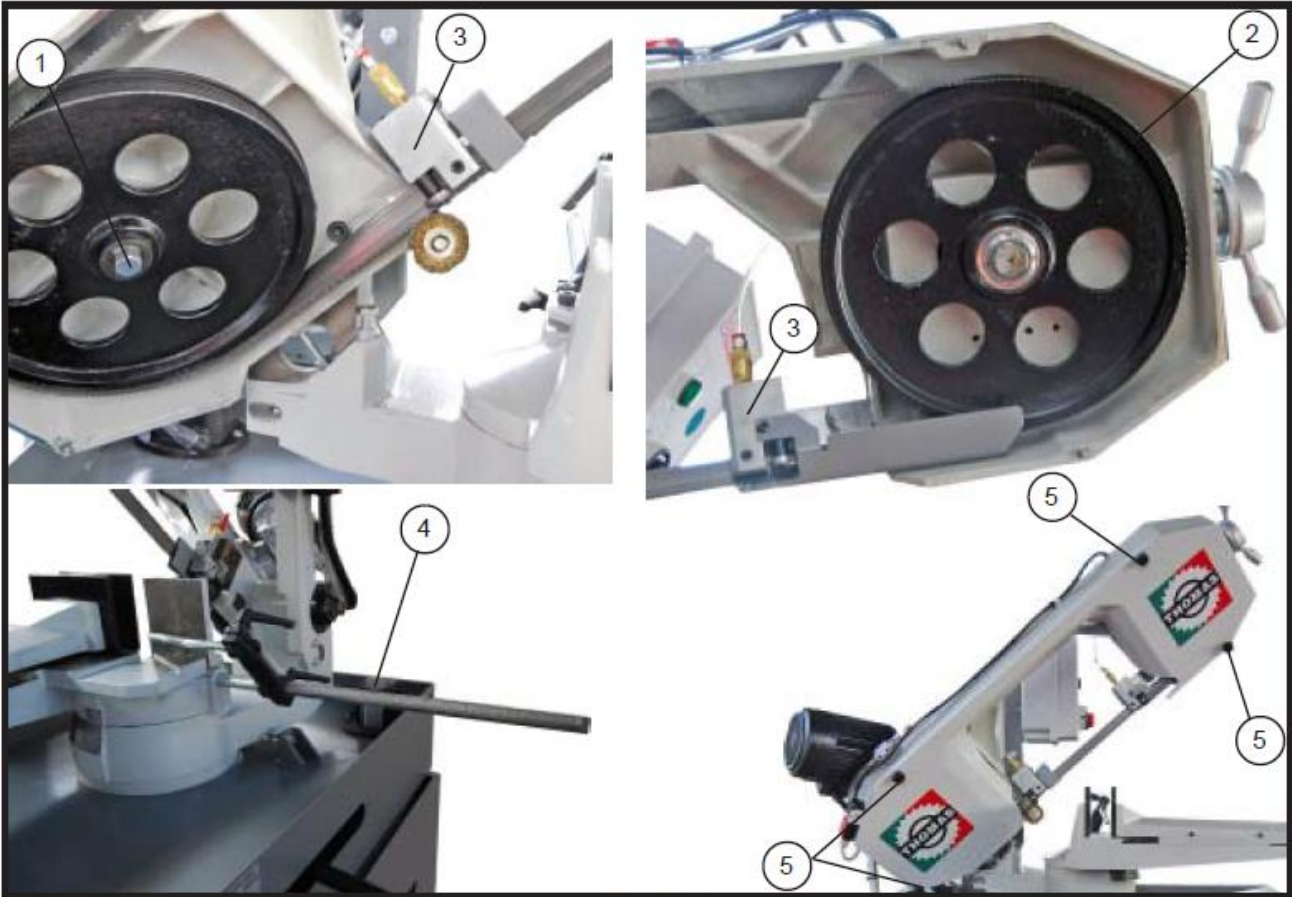

Fig. 5-12

12.2.5 MONTHLY MAINTENANCE

- Check and tight the screw (1 fig. 5-12) holding motor flywheel.
- Check and tight the ring nut (2 fig. 5-12) of the return flywheel.
- Check wear blade-guide carbide pads (3 fig. 5-12).
- Check and tight the screws (4 fig. 5-12) holding the electro-pump and the screws (5 fig. 5-12) of the sawframe cover.
- Check all safety metal guards.

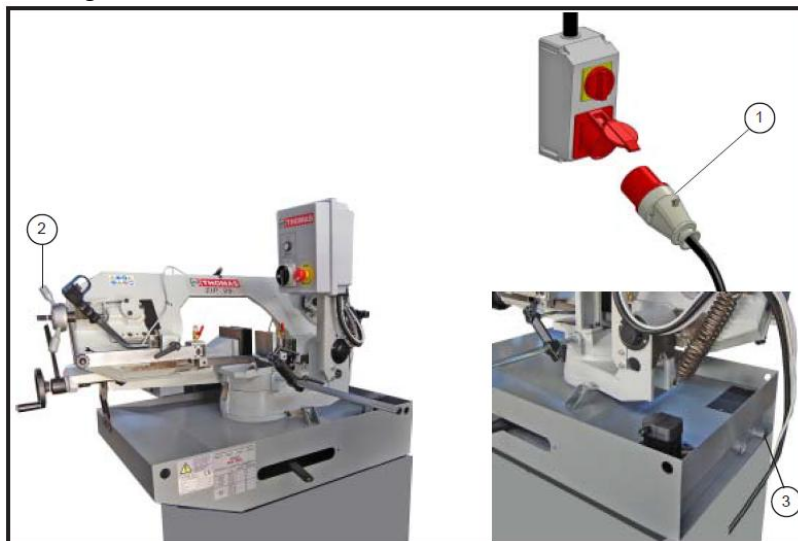

Fig. 6-12

12.2.6 BIENNIAL MAINTENANCE

(every 2000 hours)

Provide electric continuity test for the circuit of the equipotential protection.

12.2.7 OIL COOLANT LIQUID

- We advise to use SHELL LUTEM OIL ECO or any equivalent oil from any other reliable make.
- THE OIL SHOULD BE DILUTED IN WATER in one part of oil and nine parts of water.

12.2.8 OIL DISPOSAL

Oil disposal falls under strict regulations and laws. See chapter. MACHINE DISMANTLING.

12.3 SPECIAL MAINTENANCE

- Special maintenance include protection and safety devices, Gear-box, Motor, Coolant liquid Electro-pump and electric components.
- These interventions are to be undertaken from qualified technicians only.
- We advise to ask the manufacturer in case of any question.

12.4 OUT OF SERVICE

The machine does not need any particular precautions in case of long stop. Just follow the following advises :

- a) Disconnect the plug (1 fig. 7-12) from the electric power supply.
- b) Release the blade tension by turning the hand wheel (2 fig. 7-12) anticlockwise.
- c) Unhook the sawframe return spring (3 fig. 7-12).
- d) Drain the coolant liquid tank (4 fig. 7-12) completely.
- e) Clean and oil the machine accurately.
- f) Cover the machine.

After a long machine stop, before starting the machine again follow the following advises:

- a) Clean the machine.
- b) Lubricate the machine.
- c) Make the machine running idle.
- d) Test all the functional parts separately.
- e) Check the safety devices, the control panel and the efficiency of the electric components.

13 FINAL INSTRUCTIONS

13.1 GENERAL ADVISES

- Attentively observe the instructions contained in this manual and follow the CEE safety regulations as well as the national ones.
- The operator should always wear personal protection devices as prescribed from European directives and national directives too; moreover, he should follow the instructions contained in this manual (see chapter PERSONAL PROTECTION DEVICES).
- The operator should not attempt any operation on his own initiative or not of his own competence.

- During the de-installation and machine disposal, people not involved should keep away at safety distance.
- The floor around the machine should be kept clean and clear as much as possible.
- Materials of the machines and any substances contained in it, should be disposed according to the current regulations paying attention in particular to oils and electric, electronic and magnetic components.
- Before dismantling the machine, make sure that inside it there are no traces of treated materials.

13.2 MACHINE DISPOSAL

At the end of its activity, the machine can be disposed or scrapped. In this case, the operation should be effected according to the local regulations and the European laws regarding the environmental protection.

- Directive CEE 75/442 concerning the disposal of general trash;
- Directive CEE 78/319 concerning the disposal of toxic trash;
- Directive CEE 75/439 concerning the disposal of used oils.

13.2.1 GENERALS INSTRUCTION FOR MATERIALS DISPOSAL

The ferrous or cast-iron materials, made of metal only, are to be considered secondary raw material and they should be consigned to authorized organisations for re-casting after proper clearing from substances contained and classified at point 3.

Material and electric components, cables and electronic materials (magnetic boards etc.) apply to authorized organisations.

Used oil, mineral and synthetic and/or mixed, emulsion oil and grease are to be considered special trash and they should be transported and treated by authorized organizations only.

ATTENTION

Regulations and laws regarding trash are continuously changing; modification and update are expected from time to time. Therefore, the user should be informed himself about the regulations currently valid at the time of the disposal of his machine tool. In fact, the regulations may be different those above mentioned.

13.2.2 ELETCTRIC OPERATIONS

Machine status:

Machine at stop and disconnected electric plug (1 fig. 1-12).

Operators:

N. 1 electrician.

- a) Remove the plug from the power cable and remove the cable from the electric board.
- b) Cut off all the connections between the machine and the electric board.
- c) Remove the electric and electronic components from the electric box and group them separately.

13.2.3 MECHANIC OPERATIONS

Operators:

N. 1 mechanic worker.

Personal protection devices:

- Safety gloves

- Safety shoes
- Helmet

- a) Plastic materials : separate and dispose according to the current regulations.
- b) Ferrous materials : separate and dispose according to the current regulations.
- c) Light alloys; separate and dispose according to the current regulations.
- d) Oils : separate and dispose according to the current regulations.
- e) Electronic and electric components : separate and dispose according to the current regulations.

ATTENTION

It is forbidden to climb on the machine, stand or walk under it during lifting and transportation of the machine.

Access to the moving area is forbidden to any operator not involved in this operation.

All the operators should keep away at safety distance to avoid injury by machine fall or machine parts fall.

13.3 MODIFICATIONS

Parts which will be changed or added to the machine will be included in the update of the “user’s manual”.

13.4 SALE

In case of sale, the purchaser has the right to be informed about any intervention executed on the machine and trained on the machine use and maintenance; he should get all the documents including the conformity declaration.

14 MATERIAL CLASSIFICATION AND BLADE CHOICE

- Since the aim is to obtain excellent cutting quality, the various parameters such as hardness of the material, shape and thickness, transverse cutting section of the part to be cut, selection of the type of cutting blade, cutting speed and control of sawframe downfeed speed.
- These specifications must therefore be harmoniously combined in a single operating condition according to practical considerations and common sense, so as to achieve an optimum condition that does not require countless operations to prepare the machine when there are many variations in the job to be performed.
- The various problems that crop up from time to time will be solved more easily if the operator has a good knowledge of these specifications.

WE THEREFORE RECOMMEND YOU TO ALWAYS USE GENUINE "THOMAS" SPARE BLADES THAT GUARANTEE SUPERIOR QUALITY AND PERFORMANCE.

14.1 DEFINITION OF MATERIALS

The following table lists the characteristics of the materials to be cut, so as to choose the right blade to use.

14.2 BLADE SELECTION

First of all the pitch of the teeth must be chosen, in the other words, the number of teeth per inch (25,4 mm) suitable for the material to be cut, according to these criteria: - parts with a thin and/or

variable section such as profiles, pipes and plate, need close toothing, so that the number of teeth used simultaneously in cutting is from 3 to 6;

- parts with large transverse sections and solid sections need widely spaced toothing to allow for the greater volume of the chips and better tooth penetration;
- parts made of soft material or plastic (light alloys, mild bronze, teflon, wood, etc.) also require widely spaced toothing;
- pieces cut in bundles require combo tooth design.

14.3 TEETH PITCH

As already stated, this depends on the following factors:

- hardness of the material.
- dimensions of the section.
- thickness of the wall.

14.4 BLADE SPEED and DOWNFEEED SPEED

The cutting speed (m/min) and the downfeed speed (cm²/min = area travelled by the blade teeth when removing chips) are limited by the development of heat close to the tips of the teeth.

- The cutting speed is subordinate to the resistance of the material ($R = N/mm^2$), to its hardness (HRC) and to the dimensions of the widest section.

- Too high sawframe downfeed speed tends to cause the blade to deviate from the ideal cutting path, producing non rectilinear cuts on both the vertical and the horizontal plane.

The best combination of these two parameters can be seen directly examining the chips:

- Long spiral-shaped chips indicate ideal cutting.
- Very fine or pulverized chips indicate lack of feed and/or cutting pressure.
- Thick and/or blue chips indicate overload of the blade.

14.5 BLADE RUNNING-IN

When cutting for the first time, it is good practice to run in the tool making a series of cuts at a low downfeed speed (= 30-35 cm²/min on material of average dimensions with respect to the cutting capacity and solid section of normal steel with $R = 410-510 N/mm^2$), generously spraying the cutting area with lubricating coolant.



14.6 BLADE STRUCTURE

Bi-metal blades are the most commonly used. They consist in a spring-steel blade backing with electron beam or laser welded high speed steel (HSS) cutting edge. The type of stocks are classified in M2, M42, M51 and differ from each other because of their major hardness due to the increasing percentage of Cobalt (Co) and molybdenum (Mo) contained in the metal alloy.



14.7 BLADES TYPE

14.7.1 TEETH FORM and GEOMETRY

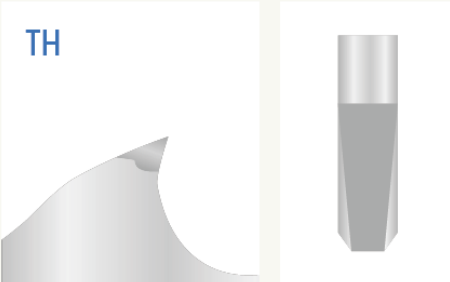
Geometria del dente / Tooth geometry

 <p>N</p>	<p>► Normale Questo dente ha l'angolo di spoglia a 0° e quindi adatto al taglio di:</p> <ul style="list-style-type: none"> – Acciai con alto contenuto di carbonio – Materiali che necessitano di bassa asportazione di truciolo – Materiali pieni a piccola sezione – Materiali profilati con spessore di parete sottile. 	<p>► Normal This tooth has a 0° cutting angle and hence suitable for cutting:</p> <ul style="list-style-type: none"> – High carbon steels – Materials with low chip removal – Small solid section materials – Thin-wall sections and profiles.
 <p>H</p>	<p>► Hook Questo dente ha angolo di spoglia positivo. È particolarmente adatto per il taglio di:</p> <ul style="list-style-type: none"> – Acciai temperati – Acciai strutturali – Materiali legati – Materiale pieno – Grosse sezioni. 	<p>► Hook This tooth has a positive cutting angle. It is particularly suitable for cutting:</p> <ul style="list-style-type: none"> – Tempered steels – Structural steels – High alloyed materials – Solid material – Thick-wall sections.
 <p>TH</p>	<p>► Trapezoidale con denti TCT Le caratteristiche tecniche del carburo unite alla particolare geometria trapezoidale rendono i denti della sega a nastro particolarmente resistenti a calore ed usura. Il dente TH è consigliato su:</p> <ul style="list-style-type: none"> – Materiali e metalli non ferrosi – Materiali contenenti nichel, titanio e cobalto – Acciai temprati con durezza fino a 62 HRC – Materiale pieno – Grosse sezioni. 	<p>► Trapezoidal with Tungsten Carbide Tips The combination of high performance material like solid carbide and the special trapezoidal tooth geometry guarantee high resistance to heat and hence wear. The TH tooth is recommended for:</p> <ul style="list-style-type: none"> – All materials including non-ferrous – Materials containing nickel, titanium and cobalt – Tempered steels with hardness up to 62 HRC – Solid steel – Thick-wall sections.

Passo del dente / Tooth pitch

 <p>F</p>	<p>► Passo Fisso Questo tipo di passo è caratterizzato dalla distanza costante tra dente e dente. Viene pertanto utilizzato:</p> <ul style="list-style-type: none"> – Per il taglio di sezioni regolari – Per il taglio di sezioni irregolari di piccole dimensioni – Da chi non deve far fronte a variazioni di dimensioni all'interno del proprio range di taglio. 	<p>► Constant Pitch This tooth pitch has a constant tooth spacing making it suitable for:</p> <ul style="list-style-type: none"> – Cutting regular sections – Cutting small sized irregular sections – Cutting same sized material constantly.
 <p>V</p>	<p>► Passo Variabile In questo particolare tipo di passo si alternano gruppi di denti con altri di differente passo. Ne consegue un aumento dei campi di utilizzo. È infatti consigliato:</p> <ul style="list-style-type: none"> – Per il taglio di sezioni irregolari (per esempio per il taglio di tubi in pacco) – A chi deve far fronte a variazioni di dimensioni all'interno della propria gamma di taglio. 	<p>► Variable Pitch This tooth pitch alternates groups of teeth with different tooth pitches and consequently the application range for this tooth form is very wide. It is suitable for:</p> <ul style="list-style-type: none"> – Cutting irregular sections (tube cutting in bundles for instance) – Cutting different sized materials constantly.

Scelta del numero di denti per pollice / Choosing the correct number of teeth per inch

► Uno degli elementi fondamentali nella selezione della sega a nastro più congeniale alle nostre esigenze è la scelta del numero di denti per pollice. Tale parametro è particolarmente importante perché ne conseguono direttamente il risultato di taglio e la durata della sega stessa. Generalmente come punto di partenza si considerano due parametri fondamentali:

1. un numero minimo di denti in presa (il passo massimo della dentatura non deve comunque essere superiore allo spessore minimo del pezzo da tagliare);
2. un numero massimo di denti in presa (deve essere tale da garantire una corretta evacuazione del truciolo per ogni singolo dente).

Anche se questo sistema non stabilisce qual è effettivamente il numero di denti più adatto, aiuta sicuramente a capire il principio di base per fare la scelta più appropriata. I parametri indispensabili per la scelta del numero di denti per pollice sono:

- a) la sezione minima e massima del materiale da tagliare,
- b) il tipo di materiale e c) il tipo di applicazione.

Nelle tabelle successive troverete le dimensioni più comuni.

► A very important aspect in band saw selection is identifying the correct tooth pitch for the given application. The correct or incorrect choice will have a direct effect on the cutting process as well as on the life-time of the blade itself. Generally, two main considerations have to be made in tooth pitch selection:

1. a minimum number of teeth in the cut (the maximum tooth pitch must never be higher than the minimum thickness of the work-piece);
2. a maximum number of teeth in the cut (the number of teeth must still allow a correct tooth load evacuation).

Even though this method does not lead you to identifying the correct tooth pitch it does allow you to understand the basic principle of tooth pitch selection enabling you to make the most appropriate tooth pitch choice. In order to make the correct selection you need:

- a) the minimum and maximum size of the section to be cut,
- b) the type of material and c) its application.

In the following tables you will find the most common sizes.

Sezioni piene / Solid sections

SEZIONE DA TAGLIARE SECTION TO BE CUT [mm]	PASSO PITCH [mm]
fino a / up to 20	10/14
10 - 30	8/12 - 8/11
20 - 50	6/10
30 - 60	5/8 - 5/7
50 - 90	4/6
80 - 150	3/4
120 - 300	2/3
250 - 600	1,4/2
400 - 1000	1,0/1,4
600 - 2000	0,75/1,25

SEZIONE DA TAGLIARE SECTION TO BE CUT [mm]	PASSO PITCH [mm]
fino a / up to 10	14
30 - 50	8
50 - 80	6
80 - 120	4
120 - 200	3
200 - 400	2
300 - 700	1,25

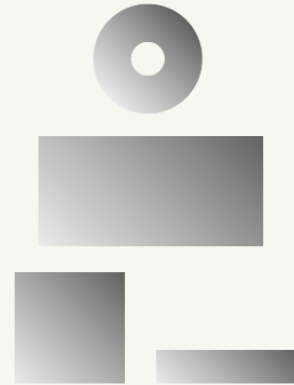

Tubi e profilati / Tubes and profiles

S [mm]	PASSO / TOOTH PITCH (TPI)										
	Ø [mm]										
	20	40	60	80	100	150	200	400	600	800	1000
2	14	14	14	14	14	10/14	10/14	8/12 - 8/11	6/10	5/8 - 5/7	5/8 - 5/7
3	14	14	10/14	10/14	10/14	8/12 - 8/11	8/12 - 8/11	6/10	5/8 - 5/7	4/6	4/6
4	14	14	10/14	10/14	8/12 - 8/11	8/12 - 8/11	8/12 - 8/11	5/8 - 5/7	4/6	4/6	4/6
6	14	10/14	8/12 - 8/11	8/12 - 8/11	8/12 - 8/11	8/12 - 8/11	5/8 - 5/7	4/6	4/6	3/4	3/4
8	14	10/14	8/12 - 8/11	8/12 - 8/11	8/12 - 8/11	6/10	5/8 - 5/7	4/6	3/4	3/4	3/4
10		8/12	6/10	6/10	6/10	5/8 - 5/7	4/6	4/6	3/4	3/4	3/4
15		8/12	6/10	6/10	5/8 - 5/7	4/6	4/6	3/4	2/3	2/3	2/3
20			6/10	5/8 - 5/7	4/6	4/6	3/4	3/4	2/3	2/3	2/3
30				4/6	4/6	3/4	3/4	2/3	2/3	2/3	2/3
50						3/4	3/4	2/3	2/3	2/3	2/3
100								2/3	1,4/2	1,4/2	1,4/2
150								2/3	1,4/2	1,4/2	1,4/2
200									1,4/2	1,0/1,4	1,0/1,4
300										1,0/1,4	0,75/1,25
400											0,75/1,25

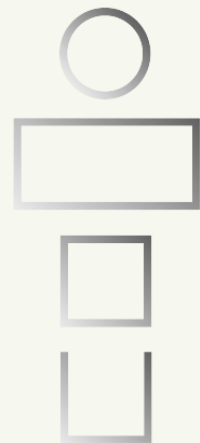

15 TROUBLE-SHOOTING

This chapter lists the probable faults and malfunctions that could occur while the machine is being used and suggests possible remedies for solving them.

Guida per la soluzione dei problemi / **Problems and Solutions** / Schnittprobleme und Lösungen

PROBLEMI PROBLEM PROBLEM	POSSIBILI CAUSE POSSIBLE CAUSES MÖGLICHE URSACHEN	SOLUZIONI SOLUTIONS LÖSUNGEN
Bava Burrs Gratbildung	Passo del dente troppo grande Tooth pitch too large Zahnteilung zu groß	Ridurre il passo (vedi pagina 6) Reduce the pitch (see page 6) Zahnteilung reduzieren (siehe Seite 6)
	Denti usurati Worn teeth Schnittkanten verschlissen	Riaffilare la sega Regrind the saw Sägeblatt schärfen
Intasamento del truciolo nel vano del dente Build-up of chip in tooth gullet Spanraumverstopfung durch Späne	Passo del dente troppo piccolo Tooth pitch too small Zahnteilung zu klein	Aumentare il passo (vedi pagina 6) Increase the pitch (see page 6) Zahnteilung erhöhen (siehe Seite 6)
	Forma del dente errata Incorrect tooth shape Zahnform ungeeignet	Vedi pagina 5 See page 5 Siehe Seite 5
	Velocità troppo elevata Speed too high Schnittgeschwindigkeit zu hoch	Vedi pagine 8-9 See page 8-9 Siehe Seiten 8-9
Rottura della lama Blade breakage Sägeblattbruch	Velocità di taglio troppo elevata Cutting speed too high Schnittgeschwindigkeit zu hoch	Vedi pagine 8-9 See page 8-9 Siehe Seiten 8-9
	Velocità di avanzamento troppo elevata Feed speed too high Vorschubgeschwindigkeit zu hoch	Vedi pagine 8-9 See page 8-9 Siehe Seiten 8-9
	Velocità di avanzamento della lama non costante Blade feed speed not constant Vorschubgeschwindigkeit des Sägeblattes unregelmäßig	Verificare la macchina Check machine Maschine überprüfen
	Errato rapporto tra velocità di avanzamento e velocità di taglio Incorrect ratio between feed and cutting speeds Ungeeignetes Verhältnis zwischen Schnittgeschwindigkeit und Vorschub	Vedi pagine 8-9 See page 8-9 Siehe Seiten 8-9
	Presenza di giochi nel serraggio del pezzo Play in piece clamping system Aufspannung des Sägeblattes unkorrekt	Verificare sistema di bloccaggio Check clamping system Maschinenflansch überprüfen
	Presenza di giochi nel serraggio della lama Play in blade clamping system Aufspannung des Schnittguts unkorrekt	Verificare la flangia Check flange Werstückspannung überprüfen
	Passo troppo piccolo Tooth pitch too small Zahnteilung zu klein	Verificare il passo (vedi pagina 6) Check pitch (see page 6) Zahnteilung überprüfen (siehe Seite 6)
	Passo troppo grande Tooth pitch too large Zahnteilung zu groß	Verificare il passo (vedi pagina 6) Check pitch (see page 6) Zahnteilung überprüfen (siehe Seite 6)
Finitura superficiale del pezzo tagliato Poor surface finish of cut piece Oberflächengüte des Schnittguts	Assente o scarsa lubro-refrigerazione Lubrication cooling absent or inadequate Kühlung und Schmierung zu gering	Verificare l'impianto Check the equipment Einrichtung überprüfen
	Denti usurati Worn teeth Schnittkanten verschlissen	Riaffilare la sega Regrind the saw Sägeblatt schärfen
	Passo del dente troppo grande Tooth pitch too large Zahnteilung zu groß	Verificare il passo (vedi pagina 6) Check pitch (see page 6) Zahnteilung überprüfen (siehe Seite 6)
	Forma del dente errata Incorrect shape of tooth Zahnform ungeeignet	Vedi pagina 5 See page 5 Siehe Seite 5
	Velocità di taglio non corretta Incorrect cutting speed Schnittgeschwindigkeit unkorrekt	Vedi pagine 8-9 See page 8-9 Siehe Seiten 8-9

15.1 BLADES AND CUTS

TOOTH BREAK

1. Too fast sawframe downfeed speed
2. Wrong cutting speed
3. Wrong tooth pitch
4. Chips sticking onto teeth and in the gullets or material that gums
5. Defects on the material or material too hard
6. Ineffective gripping of the part in the vice
7. The blade gets stuck in the material
8. Starting cut on sharp or irregular section bars
9. Poor quality blade
10. Previously broken tooth left in the cut
11. Cutting resumed on a groove made previously
12. Vibrations
13. Wrong tooth pitch or shape
14. Insufficient lubricating refrigerant or wrong emulsion
15. Teeth positioned in the direction opposite the cutting direction

SOLUTION

Decrease sawframe downfeed speed, exerting less cutting pressure. Adjust the hydraulic regulator device if mounted on the machine.

Change blade speed and/or diameter.

See Chapter **Material classification and blade selection**

PREMATURE BLADE WEAR

16. Faulty running-in of blade
17. Teeth positioned in the direction opposite the cutting direction
18. Poor quality blade
19. Too fast advance
20. Wrong cutting speed
21. Defects on the material or material too hard
22. Insufficient lubricating refrigerant or wrong emulsion

SOLUTION

See Chapter “Material classification and blade selection” in the Blade running-in section.

Turn teeth in correct direction.

Use a superior quality blade.

Decrease advance, exerting less cutting pressure. Adjust the hydraulic regulator device if mounted on the machine.

Change blade speed and/or diameter.

See Chapter **Material classification and blade selection**

BLADE BREAK

23. Faulty welding of blade
24. Too fast downfeed speed
25. Wrong cutting speed
26. Wrong tooth pitch

27. Ineffective gripping of the part in the vice
28. Blade touching material at beginning of cut
29. Blade guide blocks not regulated or dirty because of lack of maintenance
30. Blade too slack
31. Blade guide block too far from material to be cut
32. Improper position of blade on flywheels
33. Insufficient lubricating refrigerant or wrong emulsion

SOLUTION

Check distance between bearings (see Chapter “Machine adjustments” in the Blade Guide Heads section): extremely accurate guiding may cause cracks and breakage of the tooth. Clean carefully. Check that the tightening hand wheel is against the set screw that ensures ideal tightening.

Approach head as near as possible to material to be cut so that only the blade section employed in the cut is free, this will prevent deflections that would excessively stress the blade.

The back of blade rubs against the support due to deformed or poorly welded bands (tapered), causing cracks and swelling of the back contour.

Check level of liquid in the tank. Increase the flow of lubricating refrigerant, checking that the hole and the liquid outlet pipe are not blocked. Check the emulsion percentage.

15.2 ELECTRIC PROBLEMS**SOLUTION**

- Check: - phases
 - cables
 - socket
 - plug
- Voltage must arrive upstream from the fuses (terminal board).
- Check electrical efficiency and check for shorts that trigger such protections.
- Check closing of the flywheel guard.
- Check the efficiency of the device; replace it if damaged.
- Speed switch must be turned to position 1 or 2.
- Ensure that it is off and that its contacts are unbroken.
- Check mechanical efficiency; replace if damaged.
- Check that thermal relay protecting band motor is correctly connected.
- Check that the supply voltage is the same as the line voltage and that it gives a value of 24 V at output.
- Check fuse efficiency and ensure there are no short circuits causing the protection to trip.

16 ELECTRIC DIAGRAMS

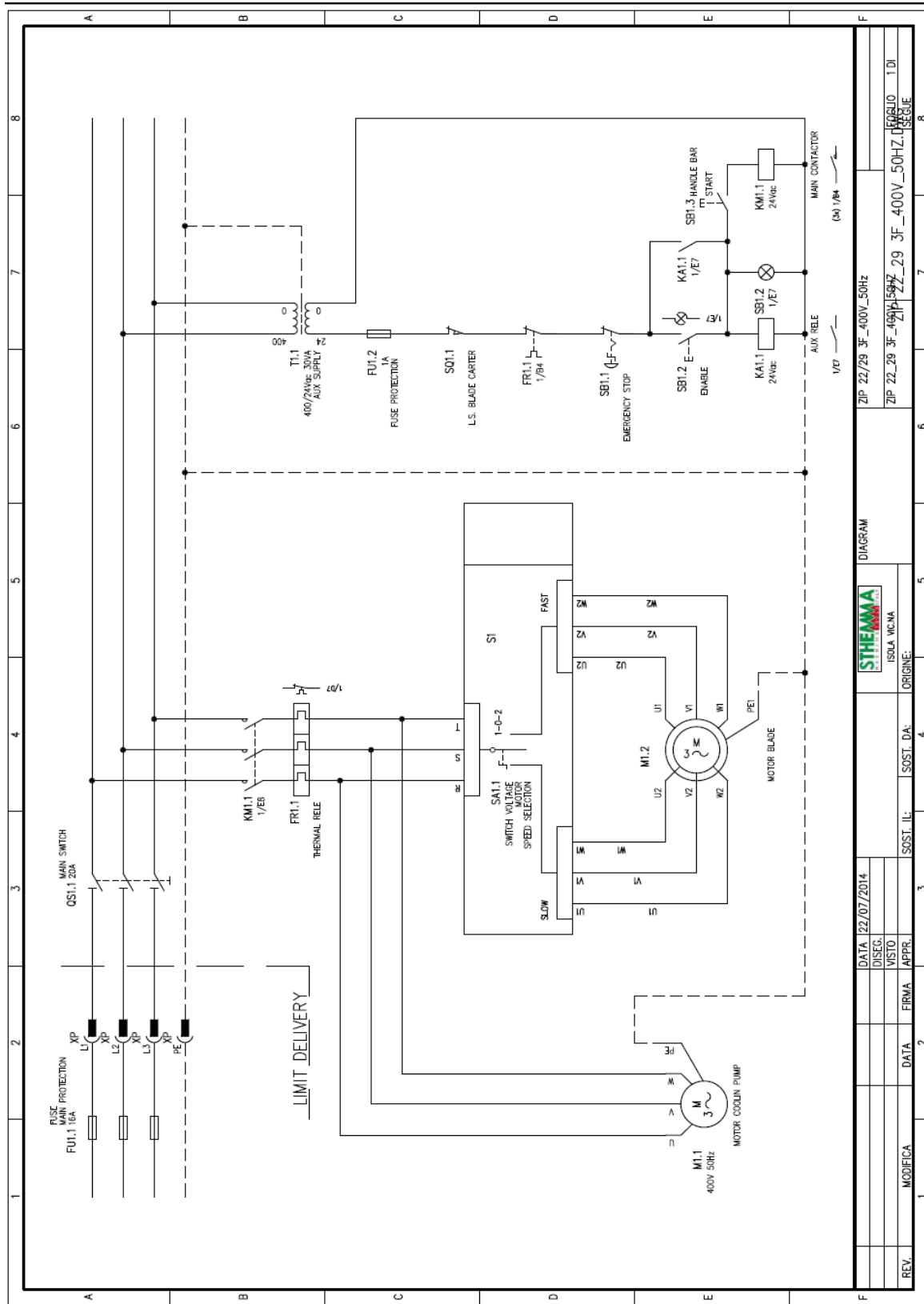

REV.	MODIFICA	DATA	FRMA	APPR.	VISTO	DISSEC.	DATA	22/07/2014
SOST. ILI.				SOST. DA:				ORIGINE:
ISOLA VICINA				ISOLA VICINA				DIAGRAM
ZIP 22_29 3F_400V_50HZ				ZIP 22_29 3F_400V_50HZ				1 DI
ZIP 22_29 3F_400V_50HZ				ZIP 22_29 3F_400V_50HZ				ISSUE

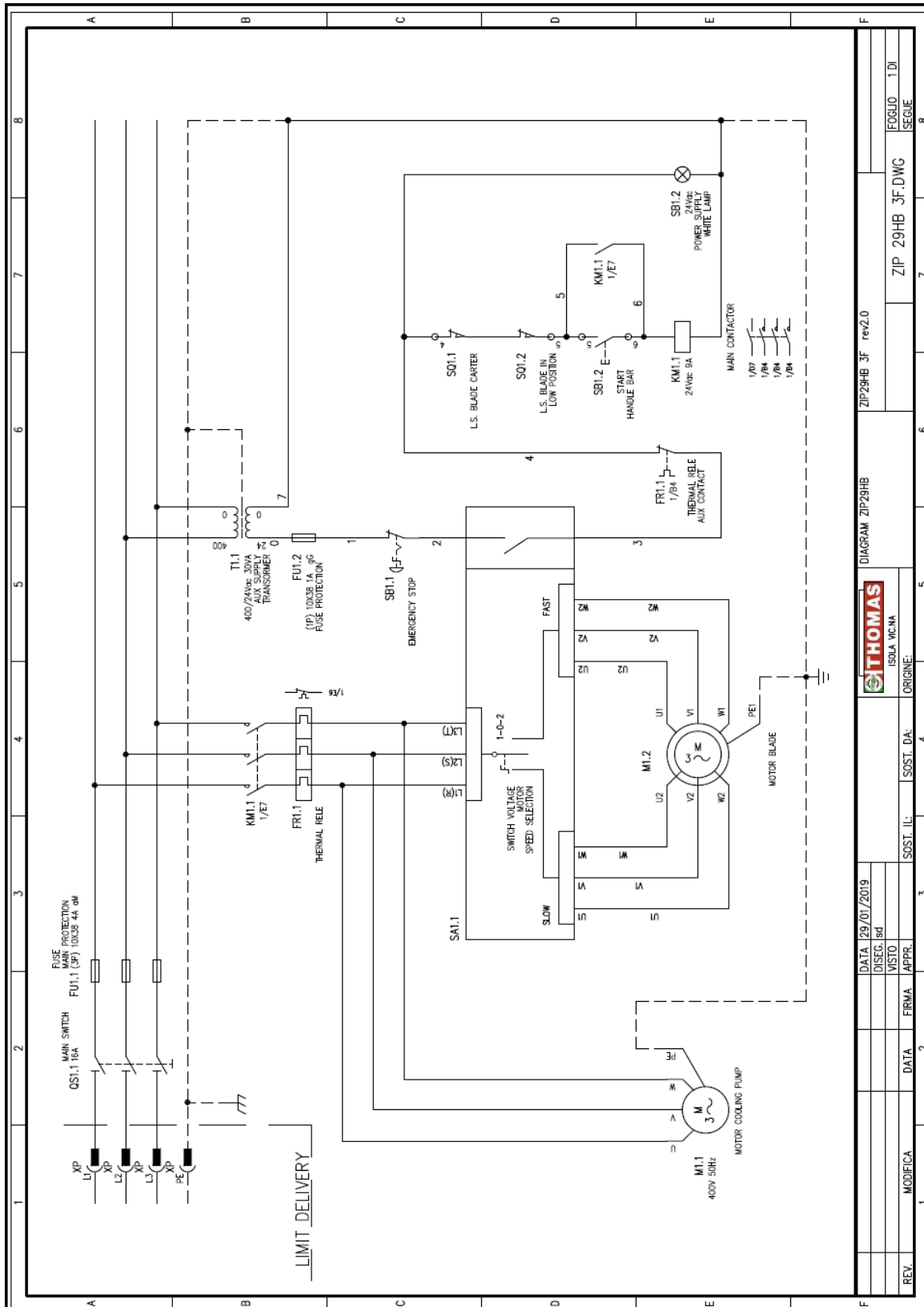

REV.	MODIFICA	DATA	FRMA	APPR.	VISTO	DISSEG. IGD	DATA 129/01/2019
SOST. IL:				SOST. DA:			
ORIGINE:				ISOLA VIC MA			
THOMAS				DIAGRAM ZIP29HB			
ZIP29HB 3F rev2.0				ZIP 29HB 3F.DWG			
1 DI				1 DI			

17 SPARE PARTS



Figura 3



Figura 4



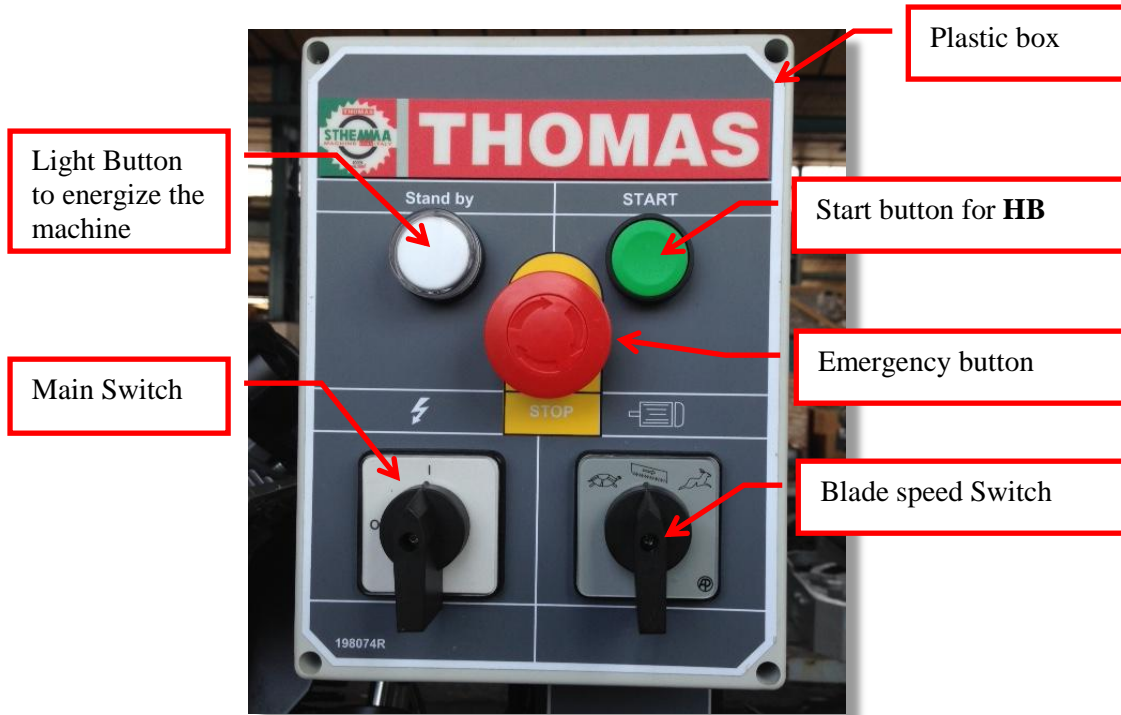



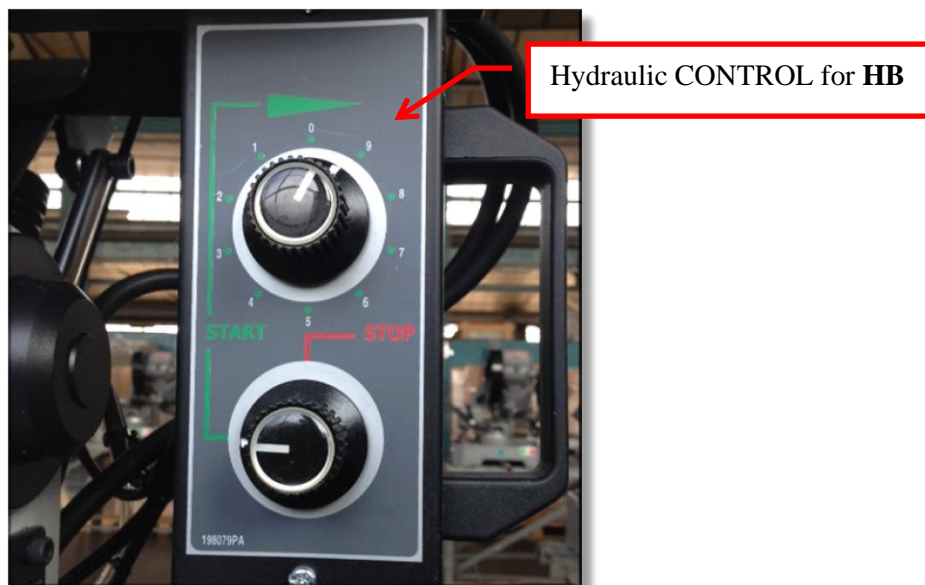
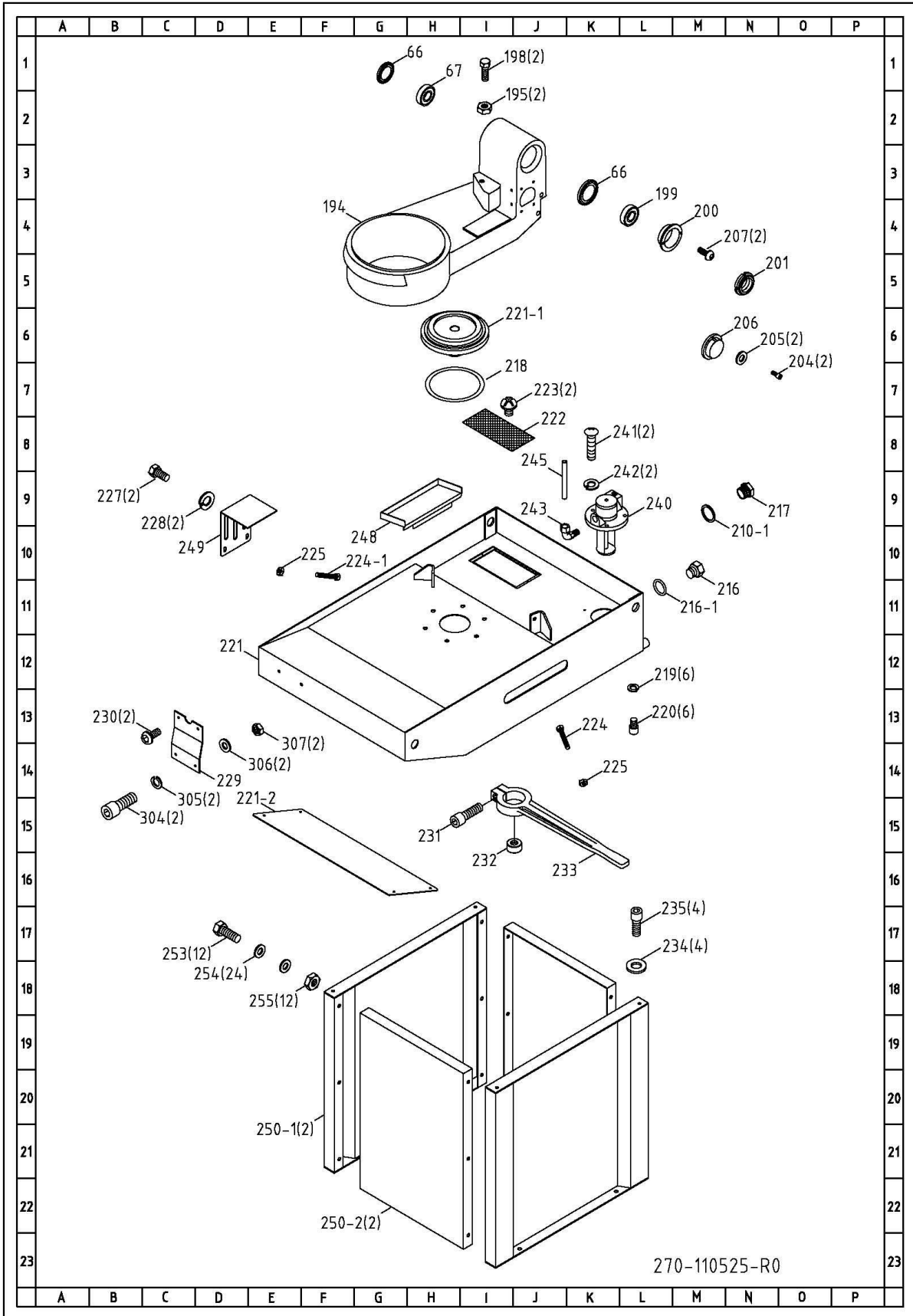
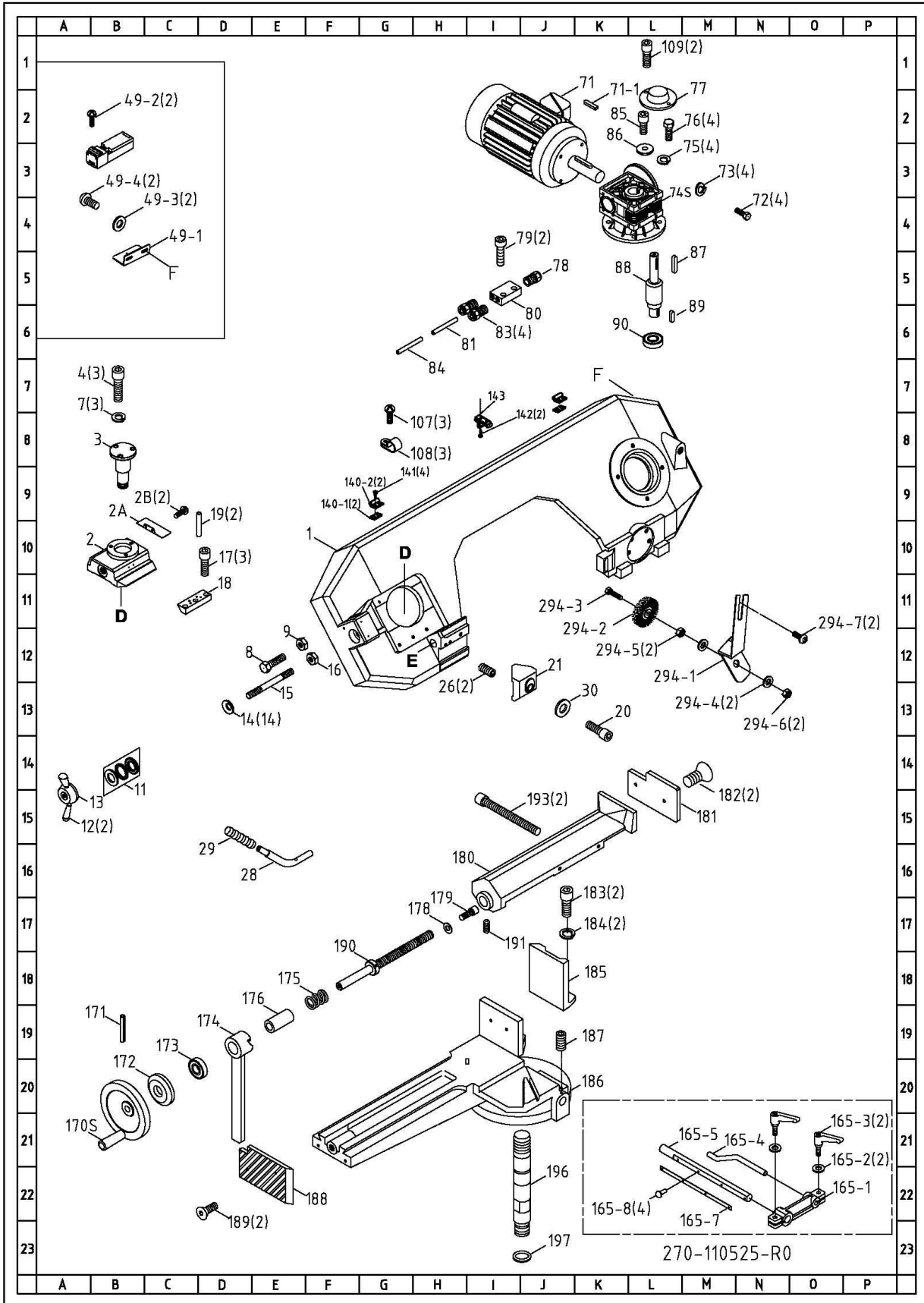
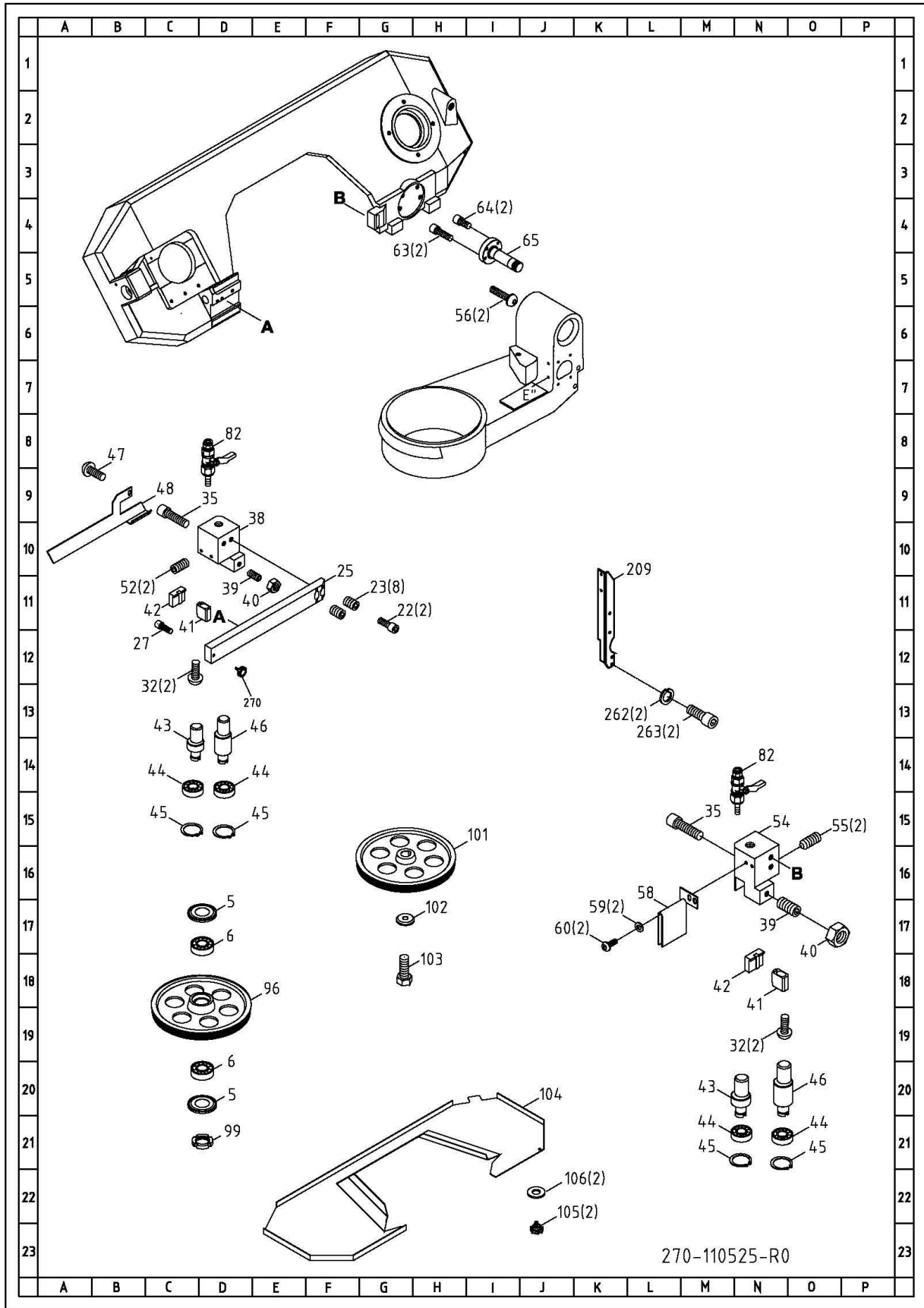

Sthemma Srl Via Monte Cimone, 1 I-36010 Zanè Italia - tel. +39 0445 296303 - www.sthemma.com