

# YCM-285C Auto Cut METAL CUTTING BAND SAW MACHINE INSTRUCTION MANUAL



## Table Of Contents

## Page No

<b>1 Safety Rules For All Tools .....</b>	<b>2</b>
<b>2 Specification .....</b>	<b>3</b>
<b>3 Features .....</b>	<b>4</b>
<b>4 Transportation &amp; Install .....</b>	<b>4</b>
<b>5 Make Proper Tooth Selection .....</b>	<b>6</b>
<b>6 BI-Metal Speeds And Feeds .....</b>	<b>6</b>
<b>7 Use Of Main Machine Parts .....</b>	<b>7</b>
<b>8 Maintaining .....</b>	<b>9</b>
<b>9.Trouble shooting .....</b>	<b>10</b>

### **CAUTION**

#### **Install saw blade and blade guard**

before use. Set proper blade tension

to prevent any danger caused by

damaged saw blade or work piece.

**WARNING: FAILURE TO FOLLOW THESE RULES  
MAY RESULT IN SERIOUS PERSONAL INJURY**

As with all machinery there are certain hazards involved with operation and use of the machine. Using the machine with respect and caution will considerably lessen the possibility of personal injury. However, if normal safety precautions are overlooked or ignored, personal injury to the operator may result.

This machine was designed for certain applications only. We strongly recommend that this machine NOT be modified and/or used for any application other than for which it was designed. If you have any questions relative to its application DO NOT use the machine until you contact with us and we have advised you.

**Your machine might not come with a power socket or plug. Before using this machine, please do ask your local dealer to install the socket or plug on the power cable end.**

**1.SAFETY RULES FOR ALL TOOLS**

**A. USER:**

- (1). **WEAR PROPER APPAREL.** No loose clothing, gloves, rings, bracelets, or other jewelry to get caught in moving parts.  
Non-slip footwear is recommended. Wear protective hair covering to contain long hair.
- (2). **ALWAYS WEAR EYE PROTECTION.** Refer to ANSLZ87.1 standard for appropriate recommendations. Also use face or dust mask if cutting operation is dusty.
- (3). **DON'T OVERREACH.** Keep proper footing and balance at all times.
- (4). **NEVER STAND ON TOOL.** Serious injury could occur if the tool is tipped or if the cutting tool is accidentally contacted.
- (5). **NEVER LEAVE TOOL RUNNING UNATTENDED. TURN POWER OFF.** Don't leave tool until it comes to a complete stop.
- (6). **DRUGS, ALCOHOL, MEDICATION.** Do not operate tool while under the influence of drug, alcohol or any medication.
- (7). **MAKE SURE TOOL IS DISCONNECTED FROM POWER SUPPLY.** While motor is being mounted, connected or reconnected.
- (8). **ALWAYS** keep hands and fingers away from the blade.
- (9). **STOP** the machine before removing chips.
- (10). **SHUT- OFF** power and clean the BAND SAW and work area before leaving the machine.
- (11). **DO NOT** Touch the cutting Blade while the machine is term on.

**B. USE OF MACHINE:**

- (1). **REMOVE ADJUSTING KEYS AND WRENCHES.** Form habit of checking to see that keys and adjusting wrenches are removed from tool before turning it "on".
- (2). **DON'T FORCE TOOL.** It will do the job better and be safer at the rate for which it was designed.
- (3). **USE RIGHT TOOL.** Don't force tool or attachment to do a job for which it was not designed.
- (4). **SECURE WORK.** Use clamps or a vise to hold work when practical. It's safer than using your hand frees both hands to operate tool.
- (5). **MAINTAIN TOOLS IN TOP CONDITION.** Keep tools sharp and clean for best and safest performance. Follow instructions for lubricating and changing accessories.
- (6). **USE RECOMMENDED ACCESSORIES.** Consult the owner's manual for recommended accessories. The use of improper accessories may cause hazards.
- (7). **AVOID ACCIDENTAL STARTING.** Make sure switch is in "OFF" position before plugging in power cord.
- (8). **DIRECTION OF FEED.** Feed work into a blade or cutter against the direction of rotation of the blade or cutter only.
- (9). **ADJUST AND POSITION** the blade guide arm before starting the cut.
- (10). **KEEP BLADE GUIDE ARM TIGHT,** A loose blade guide arm will affect sawing accuracy.
- (11). **MAKE SURE** blade speed is set correctly for material being cut.
- (12). **CHECK** for proper blade size and type.
- (13). **STOP** the machine before putting material in the vise.
- (14). **ALWAYS** have stock firmly clamped in vise before starting cut.
- (15). **GROUND ALL TOOLS.** If tool is equipped with three-prong plug, it should be plugged into a three-hole electrical receptacle. If an adapter is used to accommodate atwo prong receptacle, the adapter lug must be attached to a known ground. Never removed the third prong.

**C. ADJUSTMENT :**

MAKE all adjustments with the power off. In order to obtain the machine. precision and correct ways of adjustment while assembling, the user should read the detailed instruction in this manual.

**D. WORKING ENVIRONMENT:**

- (1). **KEEP WORK AREA CLEAN.** Cluttered areas and benches invite accidents.
- (2). **DON'T USE IN DANGEROUS ENVIRONMENT.** Don't use power tools in damp or wet locations, or expose them to rain. Keep work area well lighted.
- (3). **KEEP CHILDREN AND VISITORS AWAY.** All children and visitors should be kept a safe distance from work area.
- (4). **DON'T** install & use this machine in explosive, dangerous environment.

**E. MAINTENANCE:**

- (1). **DISCONNECT** machine from power source when making repairs.
- (2). **CHECK DAMAGED PARTS.** Before further using of the tool, a guard or other part that is damaged should be carefully checked to ensure that it will operate properly and perform its intended function. Check for alignment of moving parts, binding of moving parts, breakage of parts, mounting, and any other conditions that may affect its operation. A guard or other part that is damaged should be properly repaired or replaced.
- (3). **DISCONNECT TOOLS** before servicing and when changing accessories such as blades, bits, cutters, etc.
- (4). **MAKE SURE** that blade tension and blade tacking are properly adjusted.
- (5). **RE-CHECK** blade tension after initial cut with a new blade.
- (6). **TO PROLONG BLADE LIFE ALWAYS** release blade tension at the end of each workday.
- (7). **CHECK COOLANT DAILY** Low coolant level can cause foaming and high blade temperatures. Dirty coolant can clog pump, cause crooked. Rust, low cutting rate and permanent blade failure. Dirty coolant can cause the growth of bacteria with ensuing skin irritation.
- (8). **WHEN CUTTING MAGNESIUM NEVER** use soluble oils or emulsions (oil-water mix) as water will greatly intensify any accidental magnesium chip fire. See your industrial coolant supplier for specific coolant recommendations when cutting magnesium.
- (9). **TO PREVENT** corrosion of machined surfaces when a soluble one is used as coolant, pay particular attention to wiping dry the surfaces where fluid accumulates and does not evaporate quickly, such as between the machine bed and vise.

**F. SPECIFIED USAGE:**

This machine is used only for general metals cutting within the range of cutting capacity.

**G. NOISE:**

A weighted sound pressure level : under 80 dB.

**H. SAFETY DEVICE:**

Interlock switch on cutting area as soon as the cover of cutting area is open, machine will stop at once with the function of this switch. Do not remove this switch from machine for any reason, and check its function frequently.

**2.SPECIFICATION**

MOTOR		1.5HP	400V/50HZ/60HZ
Saw Blade Speed		35/75MPM	
Blade Size (mm)		27x0.9x2730mm	
Dimension LxWxH (mm)		1350X715X1450mm	
Packing	N.W / G.W (kgs)		265 / 290
	Measurement		1555x745x1000mm
Cutting Capacity	0°	○(mm)	240 mm
		□(mm)	260x210mm
	+ 45°	○(mm)	200 mm
		□(mm)	200x200mm
	+60°	○(mm)	125mm
		□(mm)	125x125 mm

### 3.FEARTURES:

1. This machine is useful for cutting normal steel, steel pipe, and provides cutting angle at  $+60^\circ$  and  $+45^\circ$  by the swivel head.
2. A tooth selection chart was provided on the machine for cutting reference.
3. Variable speed control gives convenient selection of speeds. (This machine comes with a standard 2-speed motor. But can be purchased with a DC driven motor as an option.)
4. This machine is using manual cutting by pulling down the saw bow by hand. Start(press) button is located at the handle of the saw bow. Motor stops when button was released.
5. Stability of the machine, plus working table height is 950 mm, conforming to human engineering.
6. The one-inch blade and carbide guide provide better result of the cutting surface and efficiency.
7. The one-piece casting and one time CNC processing provide better rigidity and precision of the machine.
8. The one-piece and full coverage blade cover conforms to CE stipulation. Well coolant fluid collection system provides clean and dry, and safety of the working area.
9. Chip pan underneath the working table prevents coolant fluid leaking and keep floor dry.
10. Coolant for cutting,, water : oil = 40 : 1 oil specification.

### 4.TRANSPORTATATION & INSTALLATION:

#### 4-1.Unpacking

1. Transportation to desired location before unpacking, please use-lifting jack. (Fig. B)
2. Transportation after unpacking, please use heavy duty fiber belt to lift up the machine.

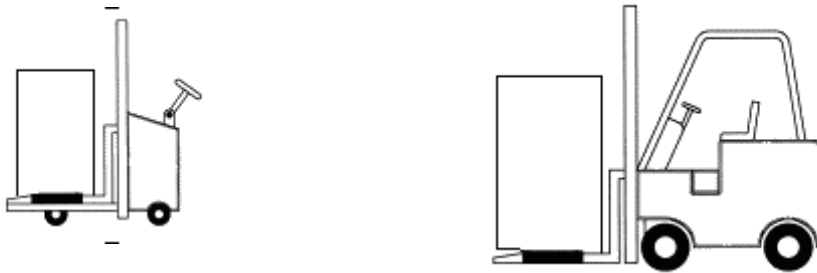

**ALLWAYS KEEP PROPER FOOTING & BALANCE WHILE MOVING THIS MACHINE.**

#### 4-2.TRANSPORTATION OF MACHINE:

As this machine weights 208kgs(458.6lbs) it is recommended that the machine be transported with help of lifting jack.

##### Transportation Recommendation:

1. **Tighten** all locks before operation.
2. **Always** keep proper footing & balance while moving this machine, and only use a heavy duty of fiber belt to lift the machine as per Fig. A.
3. **TURN OFF** the power before wiring & be sure machine is properly grounded. Overload & circuit breaker are recommended for safety wiring.
4. **Tighten** 4 bolts to base holes after machine is balanced.
5. **Check** carefully if the saw blade is running in counter-clockwise direction if not, reverse the wiring per circuit diagram, then repeat the running test.
6. **Keep** machine always out from sun, dust, wet, or raining area.

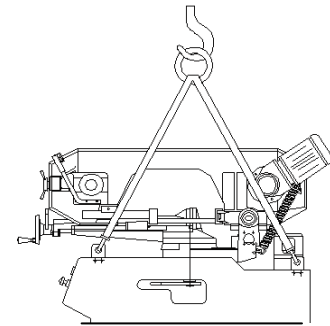

**Fig. A**

#### 4-3.Installation:

- (1) **Always** Keep proper footing & balance while moving this 208kgs machine. Hang the machine up, away from the floor, take away the 4 pads and assemble them on the auxiliary stand. Fix the machine on the auxiliary stand and lock the connection nut.
- (2) **Finish** removing this wooden case/crate from the machine. Unbolt the machine from the crate bottom.
- (3) **Position** & tighten 4 bolts into base holes properly after machine in balance.
- (4) **Turn off** the power before wiring & be sure machine is in proper grounding. Overload & circuit breaker is recommended for safety wiring.
- (5) **Keep** machine always out from sun, dust, wet, raining area.

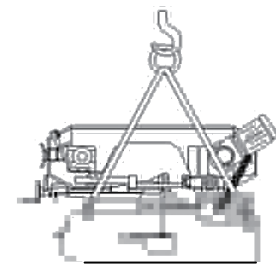

**Fig. B**

#### 4-4. CLEANING & LUBRICATING

- (1) Your machine has been coated with a heavy grease to protect it in shipping. This coating should be completely removed before operating the machine. Commercial degreaser, kerosene or similar solvent may be used to remove the grease from the machine, but avoid getting solvent on belts or other rubber parts.
- (2) After cleaning, coat all bright work with a light lubricant. Lubricate all points with a medium consistency machine oil.

#### 5. MAKE PROPER TOOTH SELECTION

For maximum cutting efficiency and lowest cost per cut, it is important to select the blade with the number of teeth per inch (TPI) for the material being cut. The material size and shape dictate tooth selection.

##### TOOTH SELECTION

You need to consider:

**The width of the cut** - That is, the distance in the cut that each tooth must travel from the point it enters the work-piece until it leaves the work-piece, and

1. The shape of the work-piece.

- **Squares, Rectangles, Flats (Symbol : ■)**  
Locate the width of cut on the chart. (Inches on the outer circle and millimeters on the inner circle.) Select the tooth pitch on the ring marked with the square shape which aligns with the width of cut.  
EXAMPLE: 6" (150mm) square, use a 2/3 Vari-Tooth.
- **Round Solids (Symbol : ●)**  
Locate the diameter of your work-piece on the chart. Select the tooth pitch on the ring marked with the round shape which aligns with the size of stock you are cutting.  
EXAMPLE: 4" (100mm) round, use a 3/4 Vari-Tooth.
- **Tubing, Pipe, Structural ( Symbol : O H ^ )**

Determine the average width of cut by dividing the area of the work-piece by the distance the saw blade must travel to finish the cut. Locate the average width of cut on the chart. Select the tooth pitch on the ring

marked with the tubing and structural shape, which aligns with the average width you are cutting.

EXAMPLE: 4"(100mm) outside diameter, 3"(75mm) inside diameter tubing.

4"(100mm) OD = 12.5 sq.in. (79cm<sup>2</sup>)  
 3"(75 mm) ID = 7.0 sq.in. (44cm<sup>2</sup>)

Area = 5.5 sq.in. (35cm<sup>2</sup>)

5.5 sq.in. (35cm<sup>2</sup>) / 4" (100mm) distance = 1.38(35mm) average width  
 1.38" (35mm), use a 4/6 Vari-Tooth

NOTE: The band speed and cutting rate recommendations presented on this chart are approximations and are to be used as a starting point for most applications. For exact sawing parameters' consult your saw blade supplier.

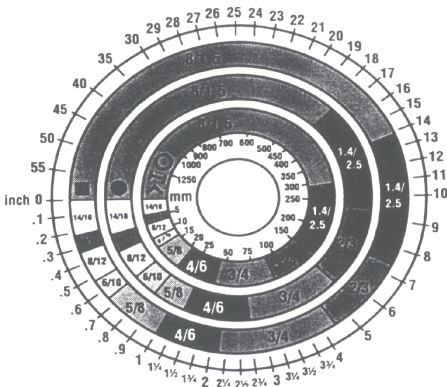

### 6. BI-METAL SPEEDS AND FEEDS

These figures are a guide to cutting 4"(100mm) material (with a 314 Vari-Tooth) when using a cutting fluid.

Increase Band Speed: 15% When cutting 1/4"(6.4mm) material (10/14 Vari-Tooth)

12% When cutting 3/4"(19 mm) material (6/10 Vari-Tooth)

10% When cutting 1-1/4"(32 mm) material(5/8 Vari-Tooth)

5% When cutting 2-1/2" (64 mm) material(4/6 Vari-Tooth)

Decrease Band Speed: 12% When cutting 8"(200mm) material(2/3 Vari-Tooth)

MATERIAL	ALLOY ASTM NO.	BAND SPEED	
		FT./MIN	M/MIN
Copper Alloy	173,932	314	96
	330,365	284	87
	623,624	264	81
	230,260,272	244	74
	280,264,632,655	244	74

	101,102,110,122,172	234	71
	1751,182,220,510	234	71
	625,706,715,934	234	71
	630	229	70
	811	214	65
Carbon Steel	1117	339	103
	1137	289	88
	1141,1144	279	85
	1141 HI STRESS	279	85
	1030	329	100
Carbon Steel	1008,1015,1020,1025	319	97
	1035	309	94
	1018,1021,1022	299	91
	1026,1513	299	91
	A36(SHAPES),1040	269	82
	1042,1541	249	76
	1044,1045	219	67
	1060	199	61
	1095	184	56
Ni-Cr-Mo Alloy Steel	8615,8620,8622	239	73
	4340,E4340,8630	219	67
	8640	199	61
	E9310	174	53
Tool Steel	A-6	199	61
	A-2	179	55
	A-10	159	49
	D-2	90	27
	H-11,H-12,H-13	189	58
Stainless Steel	420	189	58
	430	149	46
	410,502	140	43
	414	115	35
	431	95	29
	440C	80	24
	304,324	120	36
	304L	115	35
	347	110	33
	316,316L	100	30
	416	189	58

### TELLTALE CHIPS

Chips are the best indicators of correct feed force. Monitor chip information and adjust feed accordingly.

Thin or powdered chips – increase feed rate or reduce band speed.

Burned heavy chips – reduce feed rate and/or band speed.

Curly silvery and warm chips – optimum feed rate and band speed.

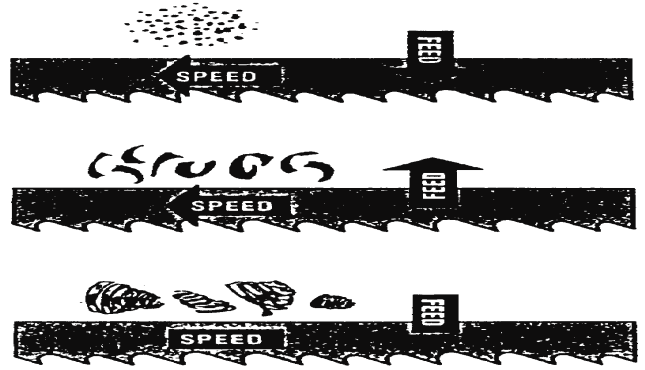

## 7.USE OF MAIN MACHINE PARTS

### 7-1.POWER SYSTEMS AND CONTROL PANEL

The electrical rating of your band saw is either with 230 volt-single phase, or 400 volt-3 phase, magnetic control. Before connecting your machine to an electrical power system, be sure the motor shaft is running in the correct direction.

We recommend that 1.5mm<sup>2</sup> fused with a 10 amp, dual element, time lag fuse, to be used to supply power to all machines regardless of their electrical rating.

Refer to the electrical wiring diagram supplied with your machine for instructions on how to connect saw to power source. Power must be cut off when wheel cover is opened or during repairing.

Please check the moving direction of the blade. If the blade is moving in the wrong direction, please re-connect the wire.

### 7-2.ADJUSTING UPWARD AND DOWNWARD TRAVEL OF SAW ARM

The downward travel of the saw arm should be adjusted so that when the saw arm is in the extreme downward position, the teeth of the blade will not touch the table surface. The stop screw (G) is used to adjust the distance between blade and table surface. After the distance is adjusted, tighten lock nut.

The screw (F) is used to adjust the saw arm upward angle, tighten lock nut.

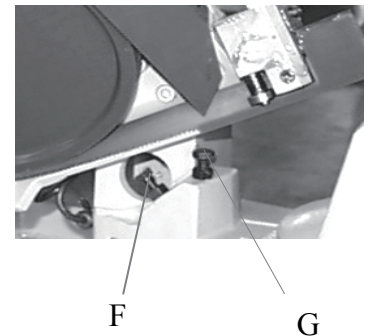

### 7-3.ADJUSTING BLADE TENSION AND BLADE TRACKING

To tension the blade, turn the blade tension handle (fig. 1)(A) clockwise. The scale is graduated to indicate blade tension of 20,000, 30,000 and 35,000 pounds per square inch (psi). For carbon blades, the blade should be tensioned at 20,000 psi. For bi-metal blades (similar to the one supplied with the machine), the blade should be tensioned at 30,000 or 35,000 psi. Always release blade tension at the end of each working day to prolong blade life. Make sure the blade is tensioned correctly before checking or adjusting tracking. The blade is tracking properly when the back of the blade is just lightly touching the wheel flanges of both wheels while the machine is running.

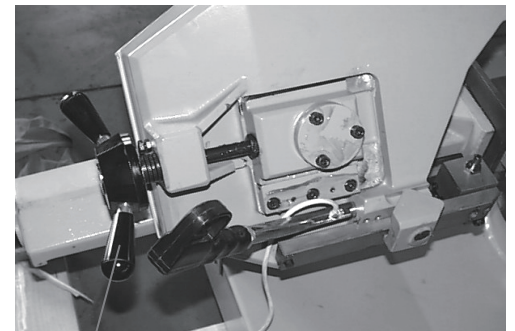

A Fig.1

### 7-4.ADJUSTING CUTTING WIDTH

First loosen screw (A) (fig.2). Move the left blade guide bar to the suitable position. Then tighten screw (A).

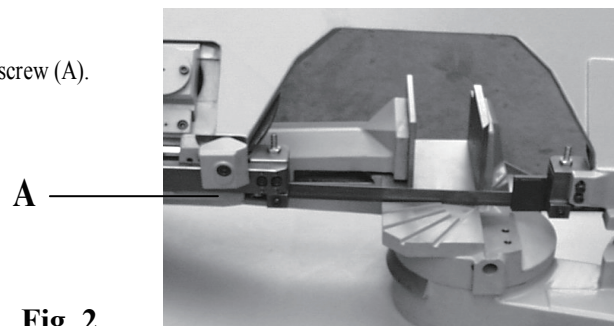
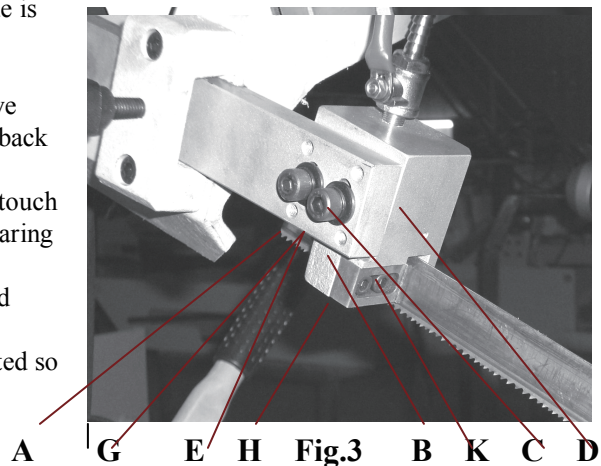

Fig. 2

### 7-5.ADJUSTING BLADE GUIDE ROLLER BEARINGS, CARBIDE BLADE GUIDES AND BACK-UP BEARINGS AND CLEARING THE CUTTING CHIP

Before making the following adjustments, make sure the blade is tracking and tensioned properly:

1. The back of the blade (A) (fig3) should ride against the back-up block (B). To adjust, loosen set screw (C) and move the guide block (D) up or down, until it lightly touches the back of the blade .
2. The saw blade (A) should also ride between and lightly touch the two blade guide roller bearings (E) (fig. 9) The front bearing (E) (fig. 9) is mounted on an eccentric, and can easily be adjusted suit blade thickness by loosening set screw (G) and turning shaft (E).
3. The carbide blade guides (H) (fig 9) should also be adjusted so they lightly touch the blade by loosening screw (K).
4. The blade guide roller bearings, carbide guides and backup bearing on holder (fig 9 ) should be adjusted in the same manner.
5. Cutting chips on the blade will be cleared by the steel brush.



### 7-6.OPERATING THE TRU-LOCK VISE SYSTEM INSTRUCTIONS

To operate, proceed as follows:

- 1) Raise the arm 2" above the work piece; close the cylinder valve to maintain the arm 2" above the work piece.
- 2) Put your work piece on the table. Move the vise handle (A) upwards to an angle of 45 degree (a-Half opened) to loosen the vise. Move the vise jaw bracket against the work piece by turning the rectangular handle (B) . Push down on the vise handle (A) to lock the work piece in position.
- 3) To loosen the work piece from the vise, hold the work piece and lift the vise handle (A) to a 90 degree position (completely opened). Remove work piece.

Fig.5

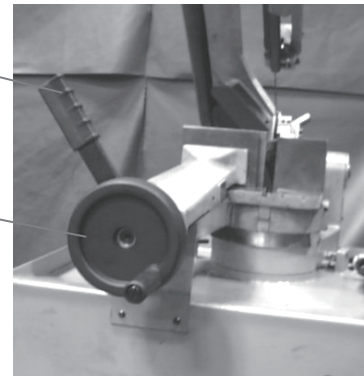

#### CONTINUED CUTTING:

When you need to cut a work piece many times, just raise the vise handle (A) to loosen and adjust work piece position. Then push down on the same handle to tighten. You can also push the vise handle (A) down first, and then tightening the vise by turning the rectangular handle (B) clockwise. After finishing the cut, you can loosen the work piece by turning rectangular handle only. This True-Lock Vise System has a 4mm tightening travel when the rectangular handle is completely opened. There is only a 2mm tightening travel necessary for normal metal materials. The operator can tighten the work piece by pushing down the vise handle (A) with a certain amount of pressure depending on hardness of work piece.

### 7-7.VARIABLE CUTTING ANGLE SELECTION

Please proceed as follows to obtain desired cutting angle. The swivel range is from 0° to 60° clockwise. Before swinging the base, make sure there is nothing in the way, or any interference.

1. Pull out the bar (A) (fig. 6) swing and hold the bar.
1. Push to turn the swivel base to desired angle. Refer to scale on (B) for degree.
2. Lock the bar (A), then start the cutting.

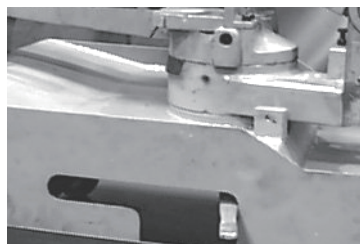
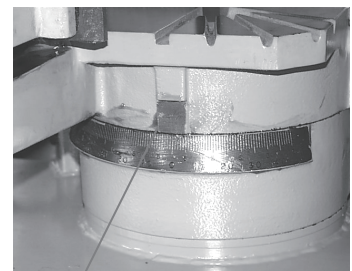

Fig.6 A



B Fig.7

1. angle. Refer to scale on (B) for degree.
2. Lock the bar (A), then start the cutting.

### 7-8.REMOVING AND INSTALLING THE BLADE

When it is necessary to replace the blade, proceed as follows:

1. Raise the saw frame about 6" and close the feed on/off knob by turning it clockwise as far as it will go (fig 8).
2. Move the blade guide arm to the right.(Fig.9).
3. Disconnect the machine from the power source. Loosen cover screw, remove cover (A), open the cover (B), remove cover (C) , then clean the chips and dirt inside the machine.
4. Release blade tension (F) (fig 9) by turning the blade tension hand-wheel counterclockwise.

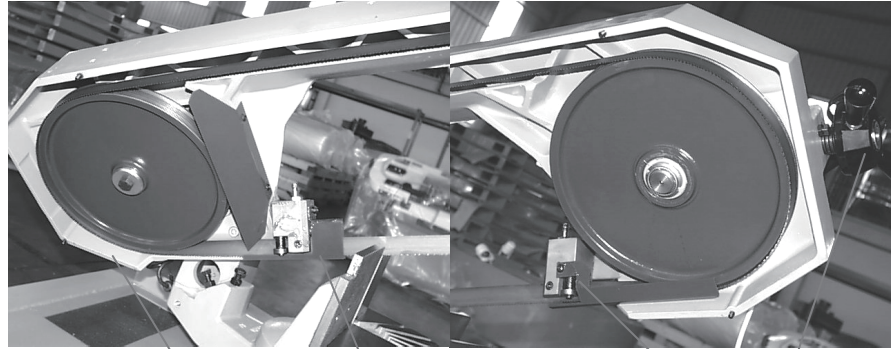

**Fig.8** A B

**Fig.9** C F

5. Remove the blade from both wheels and out of each blade guide. But remove side (B) saw blade. When totally released, then remove the side (A).
6. Make sure the teeth of the new blade are pointing in the right direction. IF necessary, turn the blade inside out.
7. Place the new blade on the wheels. In the blade guides and adjust blade tension and blade guides.

### 8.MAINTAINING

That's easier to keep machine in good condition or best performance by means of maintaining it at any time than remedy it after it is out of order.

#### (1) Daily Maintenance (by operator)

- (a) Fill the lubricant before starting machine everyday.
- (b) If the temperature of spindle caused over-heating or strange noise, stop machine immediately to check it for keeping accurate performance.
- (c) Keep work area clean; release vise, cutter, work-piece from table; switch off power source; take chip or dust away from machine and follow instructions lubrication or coating rust proof oil before leaving.

#### (2) Weekly Maintenance

- (a) Clean and coat the cross leading screw with oil.
- (b) Check to see if sliding surface and turning parts lack of lubricant. If tile lubricant is insufficient, fill it.

#### (3) Monthly Maintenance

- (a) Check if the fixed portion has been loose.
- (b) Lubricate bearing worm, and worm shaft to avoid the wearing.

#### (4) Yearly Maintenance

- (a) Adjust table to horizontal position for maintenance of accuracy.
- (b) Check electric cord, plugs, switch, at least once and a year to avoid loosening or wearing.

## 9. TROUBLE SHOOTING

Symptom	Possible Cause(s)	Corrective Action
Machine can not be started	<ol style="list-style-type: none"> <li>1. Power is not plugged; the power light on control panel is not on.</li> <li>2. Motor cannot be started; power was cut by limit switch.</li> <li>3. Operation button cannot be normally operated.</li> </ol>	<ol style="list-style-type: none"> <li>1. Check the motor specification; connect the power with correct power supply. Make sure the power light is on.</li> <li>2. Make sure the cover is in correct position.</li> <li>3. Push the emergency button; return it to original position. Then release the emergency button.</li> </ol>
Excessive Blade Breakage	<ol style="list-style-type: none"> <li>1. Materials loosen in vise.</li> <li>2. Incorrect speed or feed</li> <li>3. Blade teeth spacing too large</li> <li>4. Material too coarse</li> <li>5. Incorrect blade tension</li> <li>6. Teeth in contact with material before saw is started</li> <li>7. Blade rubs on wheel flange</li> <li>8. Miss-aligned guide bearings</li> <li>9. Blade too thick</li> <li>10. Cracking at weld</li> </ol>	<ol style="list-style-type: none"> <li>1. Clamp work securely</li> <li>2. Adjust speed or feed</li> <li>3. Replace with a small teeth spacing blade</li> <li>4. Use a blade of slow speed and small teeth spacing</li> <li>5. Adjust to where blade just does not slip on wheel</li> <li>6. Place blade in contact with work after motor is started</li> <li>7. Adjust wheel alignment</li> <li>8. Adjust guide bearings</li> <li>9. Use thinner blade</li> <li>10. Weld again, beware the welding skill.</li> </ol>
Premature Blade Dulling	<ol style="list-style-type: none"> <li>1. Teeth too coarse</li> <li>2. Too much speed</li> <li>3. Inadequate feed pressure</li> <li>4. Hard spots or scale on material</li> <li>5. Work hardening of material.</li> <li>6. Blade twist</li> <li>7. Insufficient blade</li> <li>8. Blade slide</li> </ol>	<ol style="list-style-type: none"> <li>1. Use finer teeth</li> <li>2. Decrease speed</li> <li>3. Decrease spring tension on side of saw</li> <li>4. Reduce speed, increase feed pressure</li> <li>5. Increase feed pressure by reducing spring tension</li> <li>6. Replace with a new blade, and adjust blade tension</li> <li>7. Tighten blade tension adjustable knob</li> <li>8. Tighten blade tension</li> </ol>
Unusual Wear on Side/Back of Blade	<ol style="list-style-type: none"> <li>1. Blade guides worn.</li> <li>2. Blade guide bearings not adjust properly</li> <li>3. Blade guide bearing bracket is loose</li> </ol>	<ol style="list-style-type: none"> <li>1. Replace.</li> <li>2. Adjust as per operators manual</li> <li>3. Tighten.</li> </ol>
Teeth Ripping from Blade.	<ol style="list-style-type: none"> <li>1. Tooth too coarse for work</li> <li>2. Too heavy pressure; too slow speed.</li> <li>3. Vibrating work-piece.</li> <li>4. Gullets loading</li> </ol>	<ol style="list-style-type: none"> <li>1. Use finer tooth blade.</li> <li>2. Decrease pressure, increase speed</li> <li>3. Clamp work piece securely</li> <li>4. Use coarser tooth blade or brush to remove chips.</li> </ol>
Motor running too hot	<ol style="list-style-type: none"> <li>1. Blade tension too high.</li> <li>2. Drive belt tension too high.</li> <li>3. Blade is too coarse for work</li> <li>4. Blade is too fine for work</li> <li>5. Gears aligned improperly</li> <li>6. Gears need lubrication</li> <li>7. Cut is binding blade</li> </ol>	<ol style="list-style-type: none"> <li>1. Reduce tension on blade.</li> <li>2. Reduce tension on drive belt.</li> <li>3. Use finer blade.</li> <li>4. Use coarse blade.</li> <li>5. Adjust gears so that worm is in center of gear.</li> <li>6. Check oil path.</li> <li>7. Decrease reed anti speed</li> </ol>

<p>Bad Cuts (Crooked)</p>	<ol style="list-style-type: none"> <li>1. Feed pressure too great.</li> <li>2. Guide bearings not adjusted properly</li> <li>3. Inadequate blade tension.</li> <li>4. Dull blade.</li> <li>5. Speed incorrect.</li> <li>6. Blade guides spaced out too much</li> <li>7. Blade guide assembly loose</li> <li>8. Blade truck too far away from wheel flanges</li> </ol>	<ol style="list-style-type: none"> <li>1. Reduce pressure by increasing spring tension on side of saw</li> <li>2. Adjust guide bearing, the clearance cannot greater than 0.001.</li> <li>1. Increase blade tension by adjust blade tension</li> <li>2. Replace blade</li> <li>5. Adjust speed</li> <li>6. Adjust guide space.</li> <li>7. Tighten</li> <li>8. Re-track blade according to operating instructions.</li> </ol>
<p>Bad Cuts (Rough)</p>	<ol style="list-style-type: none"> <li>1. Too much speed or feed</li> <li>2. Blade is too coarse</li> <li>3. Blade tension loose</li> </ol>	<ol style="list-style-type: none"> <li>1. Decrease speed or feed.</li> <li>2. Replace with finer blade.</li> <li>3. Adjust blade tension.</li> </ol>
<p>Blade is twisting</p>	<ol style="list-style-type: none"> <li>1. Cut is binding blade.</li> <li>2. Too much blade tension</li> </ol>	<ol style="list-style-type: none"> <li>1. Decrease reed pressure.</li> <li>2. Decrease blade tension.</li> </ol>
<p>Saw arm can not Be raised up after Pushing the raising Button</p>	<ol style="list-style-type: none"> <li>1. Improper setting of depth gauge</li> </ol>	<ol style="list-style-type: none"> <li>1. Press the emergency stop Button and RESET.</li> <li>2. Check the upper limit switch and stop round Position. Make sure the limit switch is always underneath the stop round bar.</li> <li>3. Check the oil gauge; make sure the oil is in proper range.</li> <li>4. Check the motor revolution direction; make sure the motor revolution is in clock-wise direction.</li> </ol>

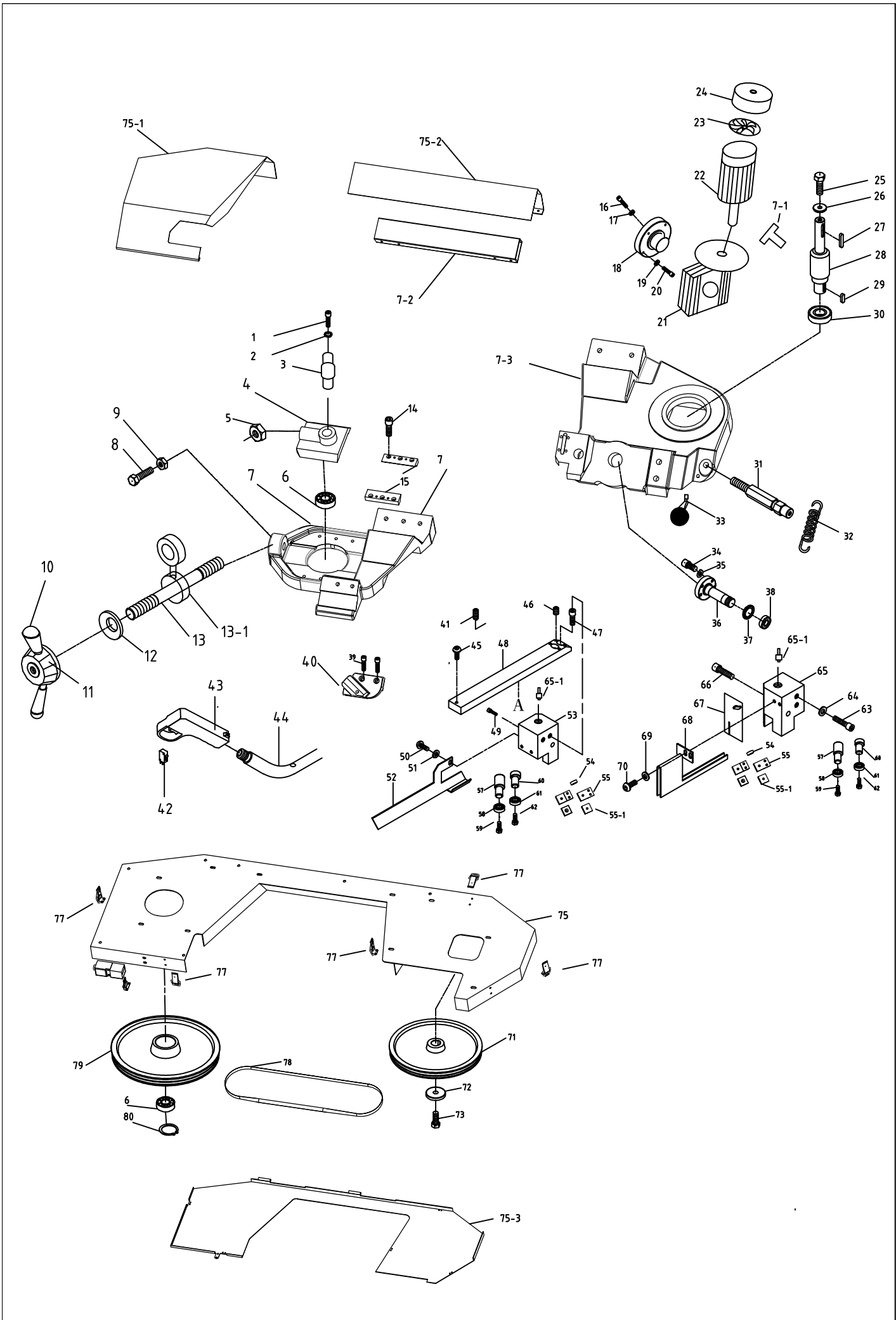

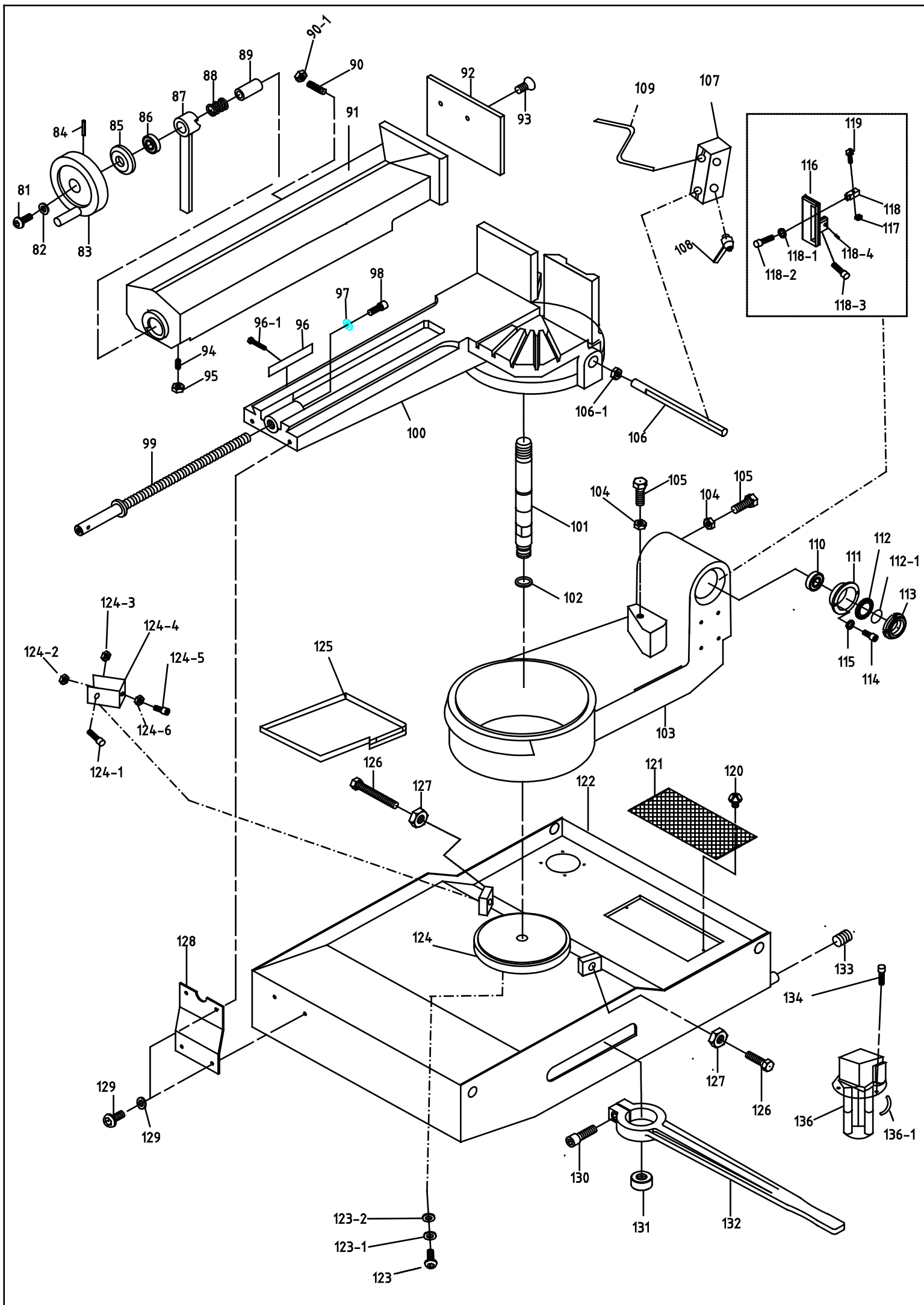

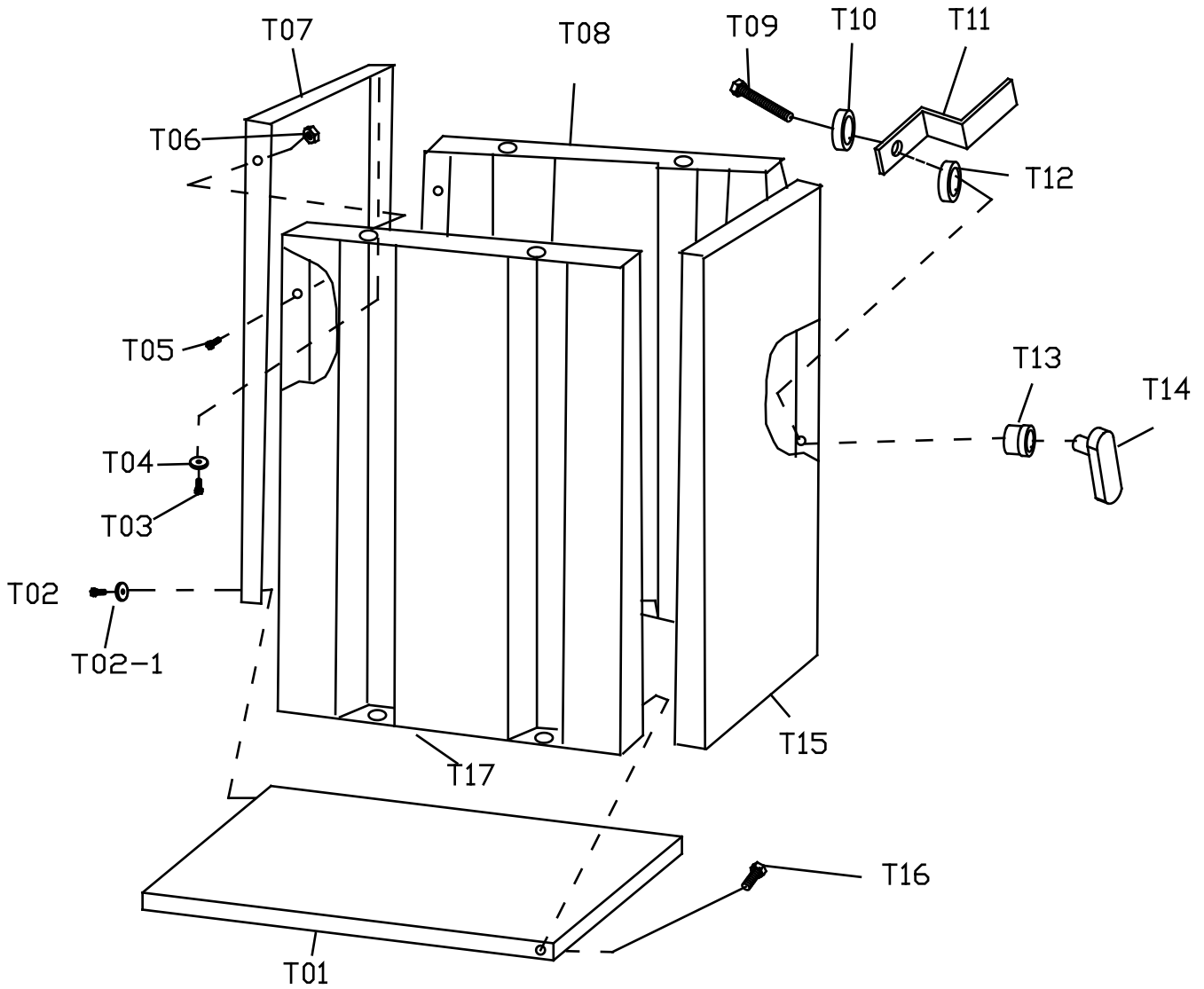
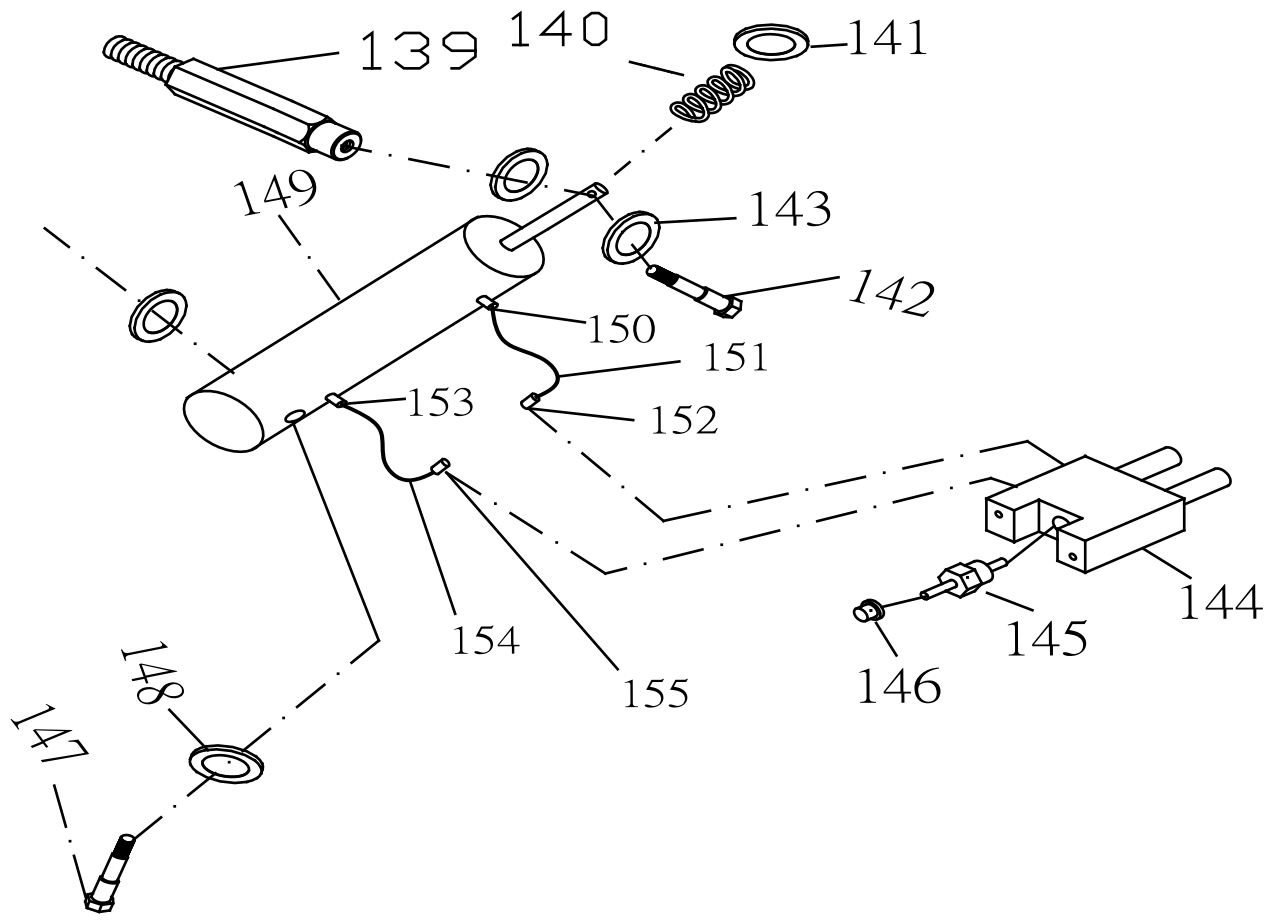

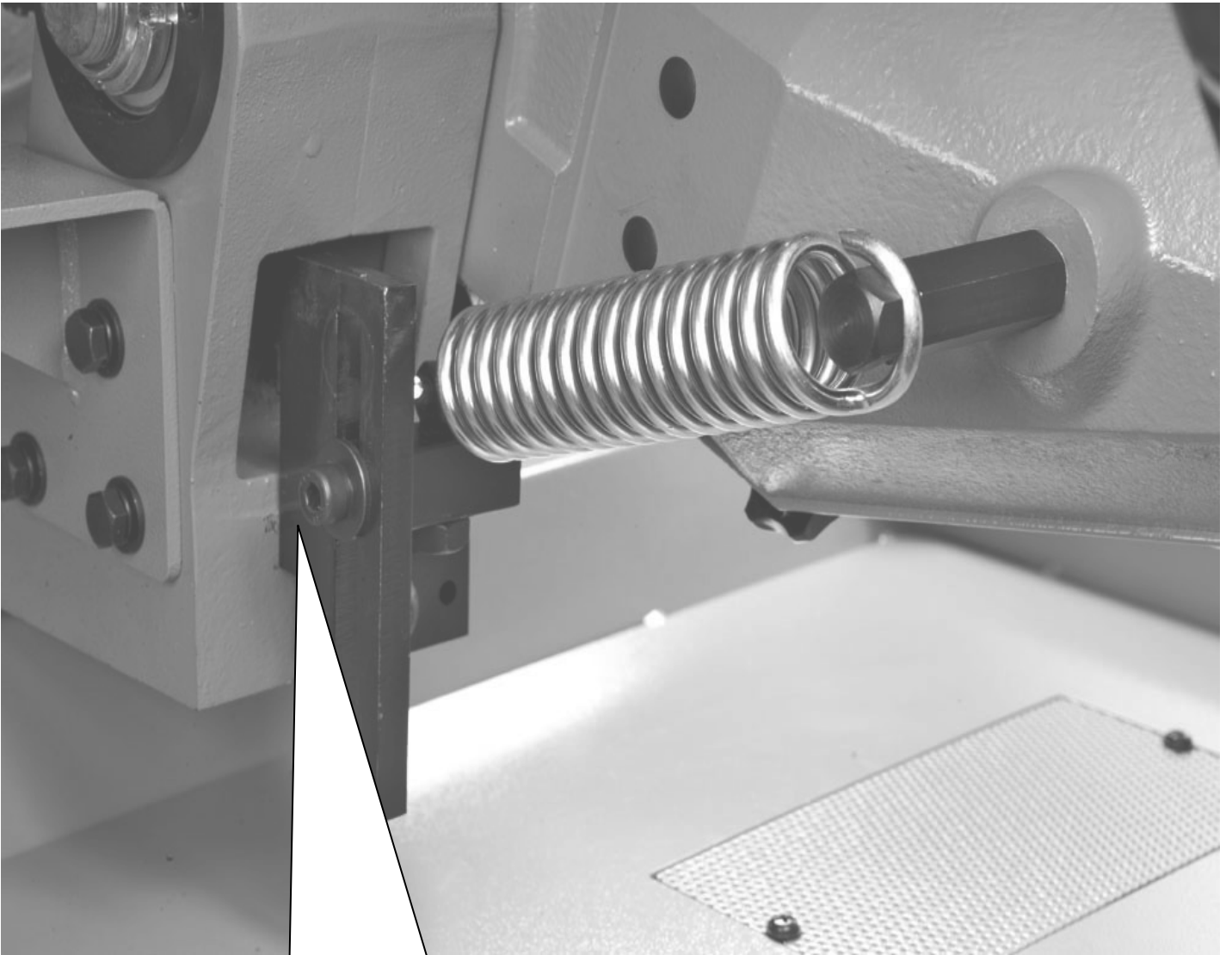

You can move the spring UP or down

UP- for auto cutting

Down –for manual cutting

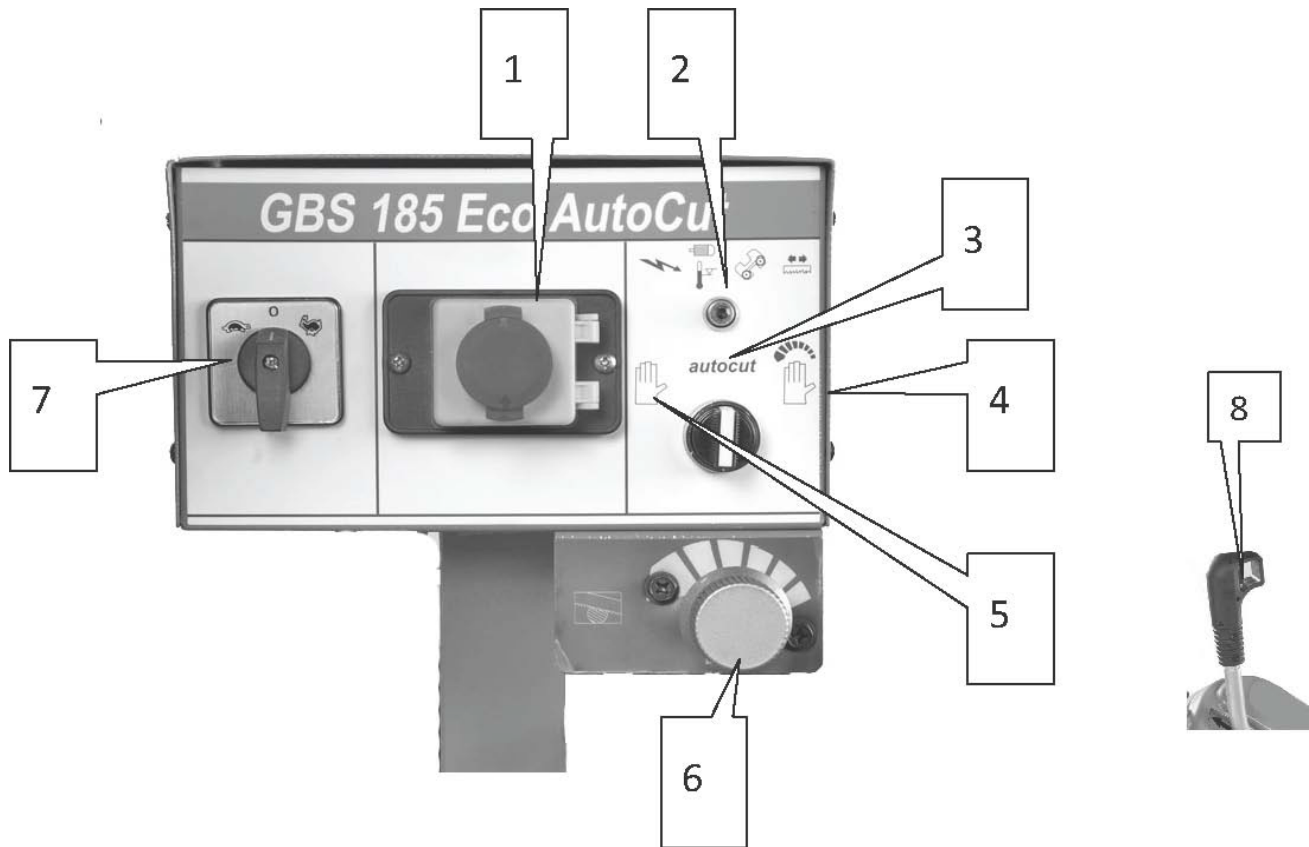

Number	Description
1	Main Switch
2	Power light
3	<b>Auto Cutting</b> Turn the switch to 3, push (8) the handle of limit switch. The machine will going down and cut by itself. Adjust No. 6 to set down-feed speed in sawframe.
4	<b>Manual Cutting</b> Turn the switch to 4, push (8) the handle of limit switch. It convert into the manual cutting. Adjust the spring and No. 6 to fit manual operation.
5	<b>Fast Moving Sawframe to approach Cutting Material</b> Turn the switch to 5, push (8) the handle of limit switch. It can move sawframe manually to near cutting material.
6	Down-feed speed can adjustable.
7	Select saw blade speed
8	Limit switch

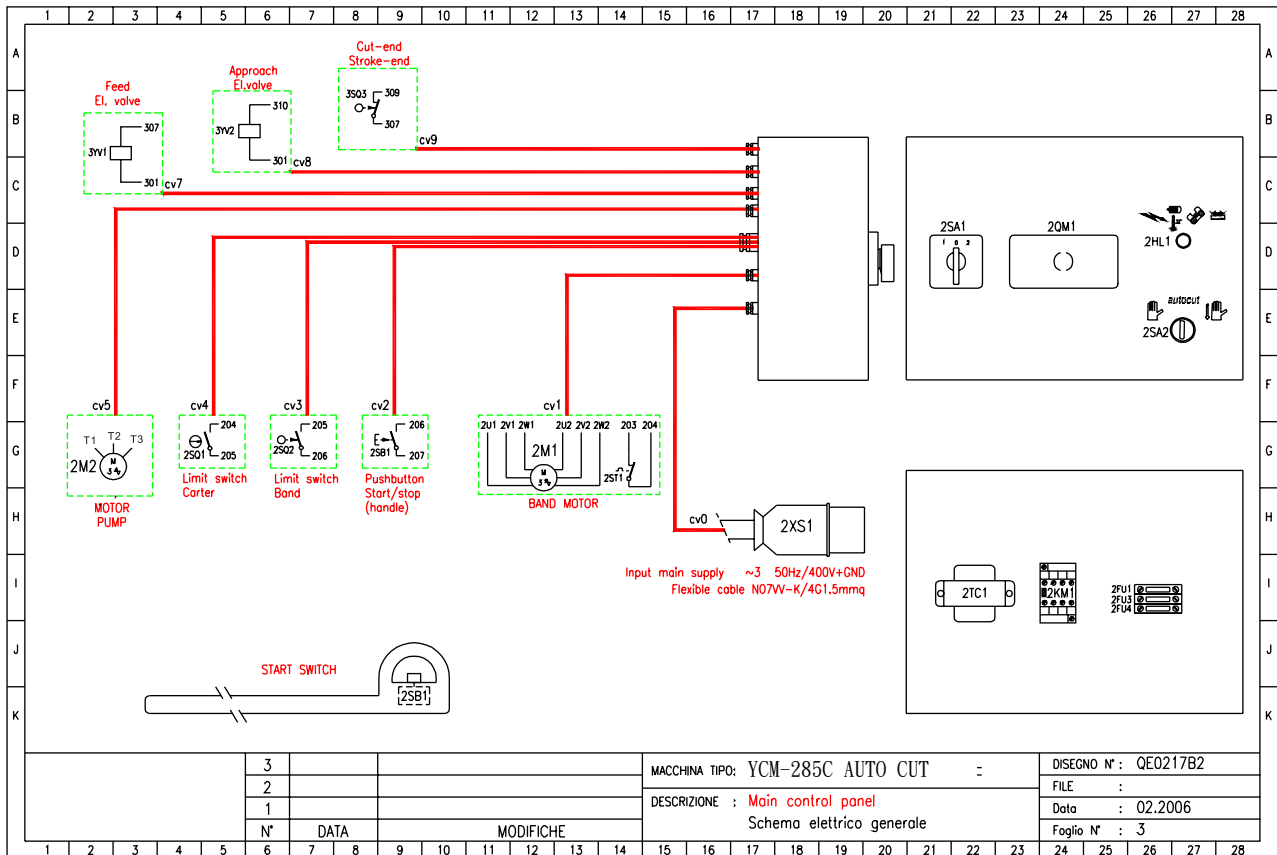
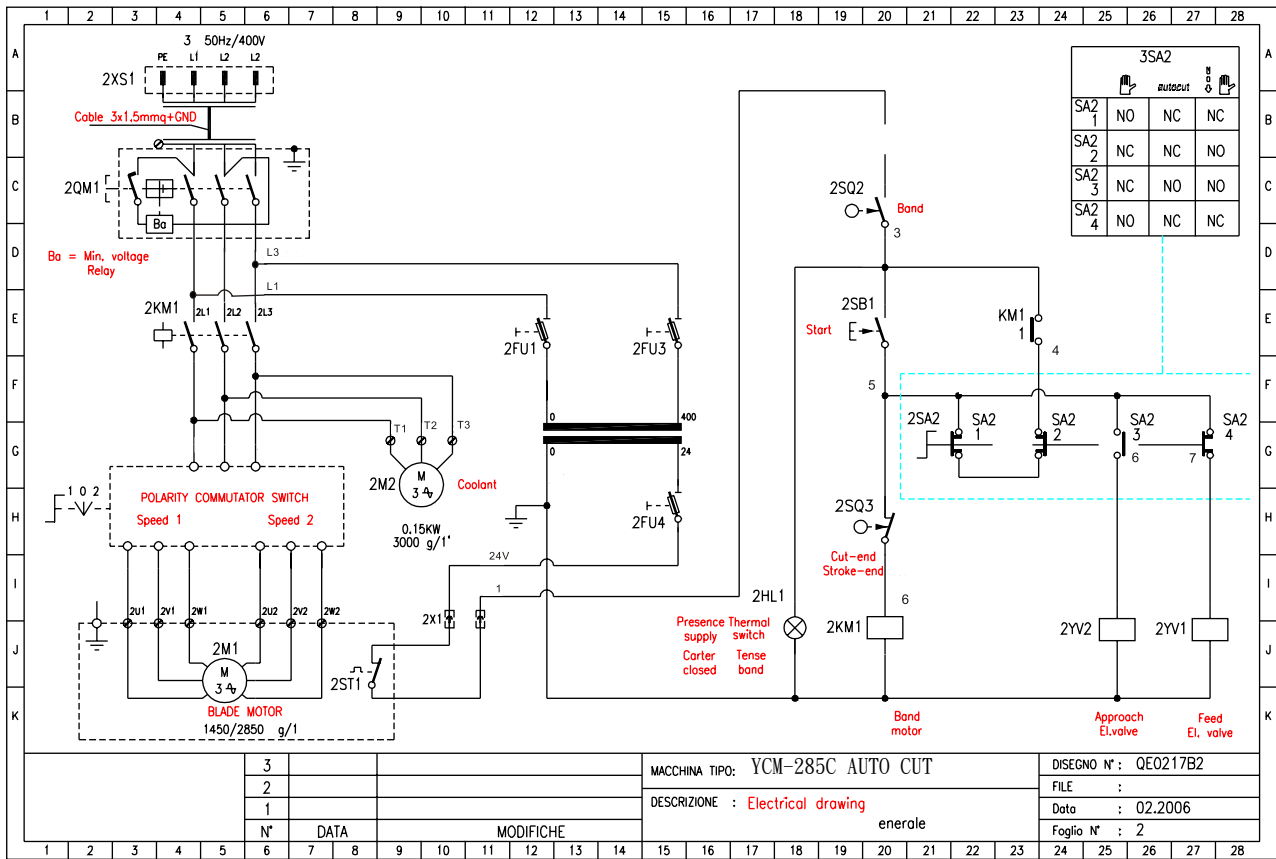

PARTS LIST				PARTS LIST				PARTS LIST				PARTS LIST			
MODEL NO. 285				MODEL NO. 285				MODEL NO. 285				MODEL NO. 285			
NO	DESCRIPTION	SPEC	QTY	NO	DESCRIPTION	QTY	NO	DESCRIPTION	SPEC	QTY	NO	DESCRIPTION	SPEC	QTY	
1	CAP Screw	M10x25	1	52	Blade Cover (Front)	1	100	Vise Jaw Bracket(Rear)		1	141	Bushing	10x55	1	
2	Washer	10*40*4	1	53	Blade Adjust (Front)	1	101	Vise Jaw Adjustable Rod		1	142	SWITCH BOARD	M10	1	
3	Shaft		1	54	Guide	2	102	O-Retainer Ring	#116	1	142-1	NUT	23X27X3	2	
4	Anchor Block		1	54-1	CAP SCREW	2	103	Swivel Arm		1	143	Washer		2	
6	Bearing	6205	2	55	Guide holder	4	104	Hex Nut	M10	2	144	Alu Set		1	
7	Left Body frame		1	55-1	Guide	4	105	Screw	M10x30	2	144-	ALU Support		1	
7-1	PIPE connect		1	56	Screw	2	106	Distance Set Rod		1	145	Macgic Valve		2	
7-2	PIPE connect		1	57	Eccentric Guide	2	106-1	NUT	M16	1	146	Knob		2	
7-3	Right Body frame		1	58	Bearing	4	107	Distance Set Bracket		1	147	CAP Screw	12x80	1	
8	Screw	6X55	1	59	Screw	2	108	Knob Nut	M8*30	1	148	Washer	12x28x3	1	
9	Screw		1	60	Eccentric Guide	2	109	N ROD		1	149	Cylinder		1	
10	knob		2	61	Bearing	2	110	Bearing	32006	1	150	Copper Connect		1	
11	Blade Tension handle		1	62	Screw	2	111	Bushing		1	151	Oil Hose		1	
12	Washer	M16	8	63	CAPSCREW	2	112	Baering Cover		1	152	Copper Connect		1	
13	Lead Screw	16X160	1	64	Spring Washer	1	113	Nut	M30x1.1	1	153	Copper Connect		1	
13-1	tention gauge		1	64-1	Washer	2	114	cap Screw	M6x15	2	154	Oil Hose		1	
14	Socket Head Screw	M8X25	3	65	Blade Adjustable (Rea	1	115	Spring Washer	M6	2	155	Copper Connect		1	
15	Fixed Block		1	65A	PIN	1	116	Spring support		1	T01	Down Plate		1	
15-1	PIN	5*25	2	65B	Bearing	1	117	NUT	M10	1	T02	screw	5/16x1/2	4	
16	CAPSCREW	M8x40	4	65-1	Valve	2	118	Spring Holder		1	T03	screw	M10X27X3	4	
18	Reducer Block		1	67	Chip Plate	1	118-1	Washer	8x23x3	1	T04	Washer		4	
19	Washer	M8	4	68	Blade Cover (Rear)	1	118-2	Screw	8x20	1	T05	Nut	Nut 5/16	8	
20	Screw	M8x25	4	69	Spring Washer	1	118-3	Screw	12x30	1	T06	Nut	Nut 5/16	1	
21	Reducer		1	70	Screw	1	118-4	Pin	6x15	1	T07	Back Plate	M6	1	
22	Motor		1	71	Drive Wheel	1	119	Spring Holder	M10	1	T08	Right support		1	
23	Fan cover		1	72	Washer	1	120	Screw	M5x8	2	T09	Handle screw		1	
24	Fan		1	73	Screw	1	121	Filter		1	T10	Bushing		1	
25	CAP Screw	M10x25	1	74	Cover Switch	1	122	Base		1	T11	Luck Plate		1	
25-1	S WASHER	M10	1	74-1	switch support	1	123	CAP Screw	M10X25	1	T12	Bushing		1	
26	Washer	10*40*4	1	74-2	Nut	1	123-1	Spring Washer	M10	1	T13	Ring		1	
27	Key	8x7x70	1	74-3	Screw	1	123-2	Washer		1	T14	Handle	M6	1	
28	Output Shaft		1	74-4	Screw	1	124	Swivel Plate	10*27*3	1	T15	Front door		1	
29	Key	7x7x30	1	75	Blade Back Cover	1	124*1	O-Retainer Ring		1	T16	screw		2	
30	Bearing	6206	1	75-1	Blade Left Cover	1	124-1	Screw		1	T17	Left support plate		1	
31	Spring Support		1	75-2	Blade up cover	1	124-2	Nut	M6X45	1					
32	Spring		1	75-3	Blade down cover	1	124-3	Nut	M8	1					
33	Steel Brush		1	76	Spring Washer	1	124-4	45 degree plate	M6	1					
33*2	Steel Brush Spring		1	77	Blade Cover plate	2	124-5	Screw		1					
33*3	Steel Brush support		1	77-1	Blade Cover plate	3	124-6	NUT	10x25	1					
33*4	Steel Brush Busing		1	78	Saw Blade	1	125	Water Plate	M10	1					
34	Screw	M6x20	2	79	Idler Wheel	1	126	Screw		1					
35	Spring Washer	M6	2	80	C-ring	1	127	Hex.Nut	M10x40	2					
36	Frame Pivot Shaft		1	81	Screw	1	128	Fixed Plate	M10	1					
37	Anti-Chip Cover		1	82	Washer	1	129	Screw		1					
38	Tapered Bearing	32006	1	83	Wheel	1	129-1	WASHER		1					
39	CAP Screw	10X55	1	84	Set Screw	1	130	Screw	6X16X1	1					
39-1	PLATE	10*27*3	1	85	Bearing Cover	1	131	Nut	M10x25	1					
40	Fixed Block		1	86	Bearing 51106	1	132	Adjustable Handle		1					
41	Set Screw	M8x8	2	87	Vise Handle	1	133	Hex Socket Plug	3/8"PT	1					
42	Switch	VM-15	2	88	Spring	1	134	Screw	M6x16	4					
43	Handel		1	89	Bushing	1	136	Pump		1					
43*1	Handel SPRING		1	90	CAP Screw	3	136-1	L-Copper	3/8X6	1					
44	Handel Pipe		1	90-1	Nut M6	1	137	Switch SET		1					
45	Screw	M10x25	1	91	Vise Jaw Bracket(Fro	1	138	Switch Bracket		1					
46	Set Screw	M6x10	2	92	Vise Plate	1	138-1	Screw	M8X16	4					
46-1	Set Screw	M6X16	2	93	Screw	1	138-2	Washer	8x16	4					
47	Screw	M8x20	2	94	CAPSCREW	1	138-3	CAP Screw	M8	2					
48	Blade adjust stick		1	96	Slide	1	138-4	S WASHER		4					
48A	Eccentric Guide Bushing		1	97	Washer	1	138-5	HANDLE		1					
48B	Blade adjust stick board		1	98	Screw	1	139	Cylinder Bracket		1					
50	Screw	M5x10	2	99	Leadscrew A	1	140	Spring	14x32x1	1					